

---

**GHANA STANDARD**

**DGS 4090:2019**

**ECE 90R02:2012**

---

**UNIFORM PROVISIONS CONCERNING THE  
APPROVAL OF REPLACEMENT BRAKE  
LINING ASSEMBLIES, DRUM BRAKE  
LININGS AND DISCS AND DRUMS FOR  
POWER-DRIVEN VEHICLES AND THEIR  
TRAILERS**

**(UNECE 90R02 Rev. 3 – 17 February 2012, IDT)**

**This document is a Draft Ghana Standard. This document shall not be used or referred to as a Ghana Standard.**

---

**ICS**

**Ref. No. DGS 4090:2019**

© Ghana Standards Authority (GSA). No part of this publication may be photocopied or otherwise reproduced without the prior permission, in writing, of the GSA.



## COPYRIGHT PROTECTED DOCUMENT

© GSA 2019

ALL RIGHTS RESERVED. The copyright of this standard is owned by the Ghana Standards Authority. Without advance written permission from the copyright owner, no part of this standard may be reproduced, distributed or transmitted in any form or by any means, including, without limitation, electronic posting on an intranet or internet or mechanical means not limited to, photocopying, microfilm, or recording by or in an information storage retrieval system. Violators may be prosecuted.

For further information, please contact:

Ghana Standards Authority  
P.O. Box MB 245 Accra-Ghana,  
Tel: (233-302) 506991-5, 500065/6,  
Fax: (233-302)500092, 500231,  
E-mail: [info@gsa.gov.gh](mailto:info@gsa.gov.gh) and [tcs@gsa.gov.gh](mailto:tcs@gsa.gov.gh)  
Website: [www.gsa.gov.gh](http://www.gsa.gov.gh)

## Foreword

The Ghana Standards Authority is the National Statutory Body responsible for the development and promulgation of Ghana Standards.

The Ghana Standards Authority is a member of the African Organization for Standardization (ARSO), the International Organization for Standardization (ISO) and an affiliate member of the International Electrotechnical Commission (IEC).

This Ghana Standard is an identical adoption of the *UNECE 90R02 Rev. 3 – 17 February 2012 - Uniform provisions concerning the approval of replacement brake lining assemblies, drum brake linings and discs and drums for power-driven vehicles and their trailers* and lays down the essential requirements to which such brake friction material must conform.

Throughout the text of this standard, read “...this UNECE Regulation...” to mean “...this Ghana Standard...”

The National Committee responsible for this standard (DGS 4090:2019) is the Technical Committee on Automobile Standards (GSA/TC 05).

This is the 1<sup>st</sup> edition.

Users of this standard should note that the standard undergoes revision from time to time and any references to it statutorily imply its latest edition.

17 February 2012

---

## Agreement

**Concerning the adoption of uniform technical prescriptions for wheeled vehicles, equipment and parts which can be fitted and/or be used on wheeled vehicles and the conditions for reciprocal recognition of approvals granted on the basis of these prescriptions\***

(Revision 2, including the amendments which entered into force on 16 October 1995)

---

## Addendum 89: Regulation No. 90

### Revision 3

Incorporating all valid text up to:

Supplement 11 to the 01 series of amendments – Date of entry into force: 24 October 2009  
Corrigendum 1 to Revision 2 of the Regulation – Date of entry into force: 23 June 2010  
02 series of amendments – Date of entry into force: 28 October 2011

**Uniform provisions concerning the approval of replacement brake lining assemblies, drum brake linings and discs and drums for power-driven vehicles and their trailers**



UNITED NATIONS

---

\* Former title of the Agreement: Agreement Concerning the Adoption of Uniform Conditions of Approval and Reciprocal Recognition of Approval for Motor Vehicle Equipment and Parts, done at Geneva on 20 March 1958.



## Regulation No. 90

### Uniform provisions concerning the approval of replacement brake lining assemblies, drum brake linings and discs and drums for power-driven vehicles and their trailers

#### Contents

	<i>Page</i>
1. Scope.....	5
2. Definitions.....	5
3. Application for approval .....	8
4. Approval.....	11
5. Specifications and tests .....	13
6. Packaging and marking .....	21
7. Modifications and extension of approval of replacement parts.....	23
8. Conformity of production.....	23
9. Penalties for non-conformity of production .....	24
10. Production definitively discontinued.....	25
11. Names and addresses of Technical Services responsible for conducting approval tests, and of Type Approval Authorities.....	25
12. Transitional provisions.....	256

#### Annexes

1A	Communication concerning the approval or extension or refusal or withdrawal of approval or production definitively discontinued of a replacement brake lining assembly or replacement drum brake lining pursuant to Regulation No. 90.....	26
1B	Communication concerning the approval or extension or refusal or withdrawal of approval or production definitively discontinued of a replacement brake disc or a replacement brake drum pursuant to Regulation No. 90 .....	28
2	Arrangements of the approval mark and approval data.....	29
3	Requirements for replacement brake lining assemblies for vehicles of categories M <sub>1</sub> , M <sub>2</sub> and N <sub>1</sub> .....	31
4	Requirements for replacement brake lining assemblies and drum brake linings for vehicles of categories M <sub>3</sub> , N <sub>2</sub> and N <sub>3</sub> .....	38
5	Requirements for replacement brake lining assemblies for vehicles of categories O <sub>1</sub> and O <sub>2</sub> .....	43
6	Requirements for replacement brake lining assemblies and drum brake linings for vehicles of categories O <sub>3</sub> and O <sub>4</sub> .....	45
7	Requirements for replacement brake lining assemblies for vehicles of category L .....	47

8	Technical prescriptions for replacement brake lining assemblies intended for the use in separate parking brake systems being independent of the vehicle service brake system.....	49
9	Special additional procedures for conformity of production.....	50
10	Illustrations.....	57
11	Requirements for replacement brake discs or brake drums for vehicles of categories M and N.....	62
12	Requirements for replacement brake discs/drums for vehicles of category O .....	79
13	Model test report for a replacement brake disc/drum.....	93

DRAFT GHANA STANDARD

## 1. Scope

- 1.1. This Regulation applies to the basic braking function of the following replacement parts<sup>1</sup>:
  - 1.1.1. Replacement brake lining assemblies intended for use in friction brakes forming part of a braking system of vehicles of category M, N, L and O which have a type approval in accordance with Regulations Nos. 13, 13-H or 78.
  - 1.1.2. Replacement drum brake linings designed to be riveted to a brake shoe for fitment to and use on vehicles of category M<sub>3</sub>, N<sub>2</sub>, N<sub>3</sub>, O<sub>3</sub> or O<sub>4</sub> having a type approval in accordance with Regulation No. 13.
  - 1.1.3. The replacement brake lining assemblies used for separate parking brake systems being independent of the vehicle service brake system will be subject only to the technical prescriptions defined in Annex 8 of this Regulation.
  - 1.1.4. Replacement brake drums and discs intended for use in friction brakes forming part of a braking system of vehicles of category M, N and O which have a type approval in accordance with Regulation No. 13 or Regulation No. 13-H.
- 1.2. Original brake discs and brake drums, fitted at time of manufacturing of the vehicle and original replacement discs and drums intended for the servicing of the vehicle are not subject to this Regulation.
- 1.3. This Regulation does not apply to "Special parts", as defined in paragraph 2.3.4.

## 2. Definitions

- 2.1. General definitions
  - 2.1.1. "*Manufacturer*" means the organization which can assume technical responsibility for the brake lining assemblies or drum brake linings or brake drums and discs and can demonstrate that it possesses the necessary means to achieve conformity of production.
  - 2.1.2. "*Replacement part*" means either a replacement brake lining assembly type, a replacement drum brake lining type, a replacement drum brake lining, a replacement brake drum or a replacement brake disc.
  - 2.1.3. "*Original part*" means either an original brake lining, an original brake lining assembly, an original drum brake lining, an original brake drum or an original brake disc.
- 2.2. Definitions regarding the approval of a replacement brake lining assembly type, a replacement drum brake lining type or a replacement drum brake lining.

---

<sup>1</sup> It does not apply to possible additional functions of replacement parts as for example speed sensing in the case of integrated speed sensing devices or guidance of the wheels in the case of integrated hubs.



- 2.2.1. "*Braking system*" has the meaning assigned in Regulation No. 13, paragraph 2.3., or Regulation No. 13-H, paragraph 2.3., or Regulation No. 78, paragraph 2.5.
- 2.2.2. "*Friction brake*" means the part of a braking system in which the forces opposing the movement of a vehicle are developed by friction between a brake lining and a wheel disc or drum moving relatively to each other.
- 2.2.3. "*Brake lining assembly*" means a component of a friction brake which is pressed against a drum or disc, respectively, to produce the friction force.
- 2.2.3.1. "*Shoe assembly*" means a brake lining assembly of a drum brake;
- 2.2.3.1.1. "*Shoe*" means a component of a shoe assembly which carries the brake lining;
- 2.2.3.2. "*Pad assembly*" means a brake lining assembly of a disc brake;
- 2.2.3.2.1. "*Backplate*" means a component of a pad assembly which carries the brake lining;
- 2.2.3.3. "*Brake lining*" means the friction material component with the shape and final dimension to be fixed on to the shoe or backplate;
- 2.2.3.4. "*Drum brake lining*" means a brake lining for a drum brake.
- 2.2.3.5. "*Friction material*" means the product of a specified mixture of materials and processes which together determine the characteristics of a brake lining;
- 2.2.4. "*Brake lining type*" means a category of brake linings which do not differ in friction material characteristics.
- 2.2.5. "*Brake lining assembly type*" means wheel sets of brake lining assemblies which do not differ in brake lining type, dimension or functional characteristics.
- 2.2.6. "*Drum brake lining type*" means wheel sets of brake lining components which after fitment to the shoes do not differ in brake lining type, dimensions or functional characteristics.
- 2.2.7. "*Original brake lining*" means a brake lining type referenced in the vehicle type approval documentation, Regulation No. 13, Annex 2, paragraph 8.1.1., Regulation No. 13-H, Annex 1, paragraph 7.1.<sup>2</sup> or Regulation No. 78, Annex 1, paragraph 5.4.
- 2.2.8. "*Original brake lining assembly*" means a brake lining assembly conforming to the data attached to a vehicle type approval documentation;
- 2.2.9. "*Replacement brake lining assembly*" means a brake lining assembly of a type approved under this Regulation as a suitable service replacement for an original brake lining assembly.
- 2.2.10. "*Original drum brake lining*" means a drum brake lining conforming to the data attached to a vehicle type approval documentation.

---

<sup>2</sup> If such brake linings are not available on the market, alternatively, brake linings listed under paragraph 8.2. may be used.

- 2.2.11. "*Replacement drum brake lining*" means a drum brake lining of a type approved under this Regulation as a suitable service replacement when fitted to a shoe for an original drum brake lining.
- 2.2.12. "*Parking brake lining assembly*" means a pad assembly or shoe assembly belonging to a parking brake system separate and independent from the service brake system.
- 2.3. Definitions regarding the approval of a replacement brake drum or a replacement brake disc.
- 2.3.1. "*Original brake disc/brake drum*"
- 2.3.1.1. In the case of motor vehicles, is a brake disc/drum covered by the vehicle braking system type approval according to Regulation No. 13 or 13-H.
- 2.3.1.2. In the case of trailers:
- (a) Is a brake disc/drum covered by the vehicle braking system type approval according to Regulation No. 13;
- (b) Is a brake disc/drum which is part of a brake for which the axle manufacturer owns a test report according to Annex 11 of Regulation No. 13.
- 2.3.2. "*Identification code*" identifies the brake discs or brake drums covered by the braking system approval according to Regulations Nos. 13 and 13-H. It contains at least the manufacturer's trade name or trademark and an identification number.
- The vehicle manufacturer shall provide on request of the technical service and/or approval authority the necessary information, which makes the link between the braking system type approval and the corresponding identification code.
- 2.3.3. Replacement parts
- 2.3.3.1. "*Original replacement brake discs and brake drums*": original brake discs/brake drums intended for servicing the vehicle and carrying an identification code as defined in paragraph 2.3.2. affixed in such a way as to be indelible and clearly legible.
- 2.3.3.2. "*Identical brake disc*" is a replacement brake disc which is chemically and physically identical in every respect with the exception of the vehicle manufacturer mark, which is absent, to the original brake disc.
- 2.3.3.3. "*Identical brake drum*" is a replacement brake drum which is chemically and physically identical in every respect with the exception of the vehicle manufacturer mark, which is absent, to the original brake drum.
- 2.3.3.4. "*Equivalent brake disc*" is a replacement brake disc which is identical to the original brake disc in respect to all dimensions, geometric features and basic design and is also from the same material sub-group as the original brake disc as defined in paragraph 5.3.3.2.
- 2.3.3.5. "*Equivalent brake drum*" is a replacement brake drum which is identical to the original brake drum in respect to all dimensions, geometric features and basic design and is also from the same material sub-group as the original brake drum as defined in paragraph 5.3.3.2.

- 2.3.3.6. "*Interchangeable brake disc*" is a replacement brake disc which has the same interface dimensions as the original brake disc but may differ from the original brake disc in terms of its design, material composition and mechanical properties.
- 2.3.3.7. "*Interchangeable brake drum*" is a replacement brake drum which has the same interface dimensions as the original brake drum but may differ from the original brake drum in terms of its design, material composition and mechanical properties.
- 2.3.4. "*Special brake disc/drum*" means a replacement brake disc/drum not covered by paragraphs 2.3.1. to 2.3.3.
- 2.3.5. "*Functional dimensions*": all the measurements that are relevant with regard to the fitting and functioning of the components of the braking system (see paragraph 5.3.7.1. and Annex 10).
- 2.3.6. "*Type of brake disc/drum*": brake discs or drums having the same basic design and material group in accordance with the classification criteria pursuant to paragraphs 5.3.5.1. or 5.3.5.2. as appropriate.
- 2.3.7. "*Test group*": type of brake discs/drums having the same characteristics pursuant to paragraph 5.3.6.
- 2.3.8. "*Variant*": individual brake disc/drum within a given test group.
- 2.3.9. "*Material*": chemical composition and mechanical properties as per paragraph 3.4.1.2.
- 2.3.10. "*Material group*": e.g. grey cast iron, steel, aluminum, etc.
- 2.3.11. "*Material sub-group*": one of the sub-group defined in paragraph 5.3.3.2.
- 2.3.12. "*Minimum thickness*": the thickness of the brake disc is the point at which replacement becomes necessary.
- 2.3.13. "*Maximum inside diameter*": the maximum inside diameter of the brake drum is the point at which replacement becomes necessary.

### **3. Application for approval**

- 3.1. An application for approval of a replacement part for (a) specific vehicle type(s) shall be submitted by the manufacturer of the replacement part or his duly accredited representative.
- 3.2. An application may be submitted by the holder of (a) vehicle type approval(s) to Regulation No. 13 or 13-H or 78 in respect of replacement part conforming to the type recorded in the vehicle type approval(s) documentation.
- 3.3. In the case of an application regarding the approval of a replacement brake lining assembly type, a replacement drum brake lining type or a replacement drum brake lining:
- 3.3.1. An application for approval shall be accompanied, in triplicate, by a description of the replacement brake lining assembly or replacement drum brake lining with regard to the items specified in Annex 1 to this Regulation, and by the following particulars:

- 3.3.1.1. Diagrams showing functional dimensions of the replacement brake lining assembly or replacement drum brake lining;
- 3.3.1.2. An indication of the positions of the replacement brake lining assembly or replacement drum brake lining on the vehicles for which approval to fit is sought.
- 3.3.2. Brake lining assemblies or drum brake linings of the type for which approval is sought shall be made available in sufficient quantity to perform the approval tests.
- 3.3.3. The applicant shall agree with and make available to the technical service responsible for conducting approval tests the suitable representative vehicle(s) and/or brake(s).
- 3.3.4. The Competent Authority shall verify the existence of satisfactory arrangements for ensuring effective control of the conformity of production before type approval is granted.
  - 3.3.4.1. The applicant shall submit values for friction behaviour in accordance with Annex 9, Part A, paragraph 2.4.1. or 3.4.1. respectively of this Regulation.
- 3.4. In the case of an application regarding the approval of a replacement brake drum or a replacement brake disc.
  - 3.4.1. An application for approval shall be accompanied, in triplicate, by a description of replacement brake drum or a replacement brake disc with regard to the items specified in Annex 1B to this Regulation, and by the following particulars:
    - 3.4.1.1. Disc or drum drawing(s) including the dimensions of the features mentioned in paragraph 5.3.7.1., together with tolerances, and any accompanying accessories:
      - (a) Location and nature of the marking pursuant to paragraph 6.2.2. – dimensions in mm;
      - (b) Weight in grams;
      - (c) Material.
    - 3.4.1.2. Component description

The manufacturer shall provide a component description containing at least the following information:

      - (a) The manufacturer of the unmachined part;
      - (b) A description of the process of manufacture of the unmachined part;
      - (c) Proof of the reliability of the process (e.g. freedom from cracks and cavities, dimensions);
      - (d) Material composition, specifically:
        - (i) Chemical composition;
        - (ii) Microstructure;
        - (iii) Mechanical properties:
          - a. Brinell hardness pursuant to ISO 6506-1:2005;
          - b. Tensile strength in accordance with ISO 6892:1998.
      - (e) Corrosion or surface protection;

- (f) Description of the balancing measures, maximum permissible balance error;
- (g) Amount of wear allowed (minimum thickness in the case of brake discs or the maximum internal diameter in the case of brake drums).

The applicant shall submit the information and specifications outlined in Annex 9, Part B, paragraph 2.5. of this Regulation.

3.4.2. Conformity of production

The competent authority shall verify the existence of satisfactory arrangements for ensuring effective control of the conformity of production before type approval is granted.

3.4.2.1. The applicant shall submit the documentation in accordance with Annex 9, Part B, paragraph 2. of this Regulation.

3.4.3. Sample quantities and usage

3.4.3.1. A minimum number of disc or drum samples – of the design for which approval is requested – shall be provided, as shown in the following table.

The table also shows the recommended use of the samples.

Item No.	Check/Test	Sample Number						Remarks
		1	2	3	4	5	6	
1	Geometric check Paragraphs 5.3.3.1., 5.3.4.1.	x	x	x	x	x	x	
2	Material check Paragraphs 5.3.3.2., 5.3.4.2.	x	x					
3	Balancing provisions check Paragraph 5.3.7.2.			x	x	x	x	
4	Wear condition marking check Paragraph 5.3.7.3.			x	x	x	x	
5	Integrity test – thermal fatigue Paragraphs 4.1.1., 4.2.1. of Annex 11, 4.1.1., 4.2.1. of Annex 12				x	x		
6	Integrity test – high load test Paragraphs 4.1.2., 4.2.2. of Annex 11, and paragraphs 4.1.2., 4.2.2. of Annex 12			x				
7	Service brake vehicle performance test Paragraph 2.2. of Annex 11, Paragraph 2.2. of Annex 12						Pair of discs	Either front or rear axle

Item No.	Check/Test	Sample Number					Remarks
8	Parking brake vehicle performance test Paragraph 2.3. of Annex 11, Paragraph 2.3. of Annex 12					Pair of discs	If applicable
9	Service brake dynamometer performance test Paragraph 3.3. of Annex 11, paragraph 3.3. of Annex 12					x	Alternative to vehicle test

- 3.4.3.2. Each disc and drum, other than those using geometric and material checks, shall be accompanied by the appropriate number of the suitable brake lining assemblies which have an approval to Regulation No. 13, 13-H or 90.
- 3.4.3.3. In the case where a comparison with the original brake disc or brake drum is required, an axle set of original brake discs or original brake drum, as applicable, shall be provided.
- 3.4.3.4. Where an equivalent replacement disc/drum approval is sought, two original brake disc/drum or original replacement brake disc/drum samples shall be provided for dimensional and material comparisons.
- 3.4.3.5. Where an interchangeable replacement disc/drum approval is sought, two original brake disc/drum or original replacement brake disc/drum samples shall be provided for dimensional comparison.

## 4. Approval

- 4.1. If the replacement part submitted for approval pursuant to this Regulation meet the requirements of paragraph 5. below, approval of the replacement part shall be granted.
- 4.1.1. In the case of replacement brake lining assemblies for vehicles of category L with a combined braking system in the meaning of paragraph 2.9. of Regulation No. 78, the approval must be restricted to the brake lining assembly combination(s) on the axles of the vehicle having been tested according to Annex 7 of this Regulation.
- 4.2. To each replacement part approved there shall be assigned an approval number comprising four groups of digits:
- 4.2.1. The first two digits (at present 02 for the Regulation in its 02 series of amendments) shall indicate the series of amendments incorporating the most recent major technical amendments made to the Regulation at the time of issue of the approval.
- 4.2.2. The following single digit shall indicate the category of the replacement part as follows:
- A Replacement brake lining assembly
  - B Replacement drum brake lining
  - C Replacement brake disc
  - D Replacement brake drum

4.2.3. The next four digits shall indicate the manufacture and the type of the brake lining, the type of disc or the type of drum.

A suffix of four digits shall indicate:

- (a) The shoe or back plate or specific dimension in the case of drum brake linings;
- (b) The variant in the case of a replacement disc or replacement drum.

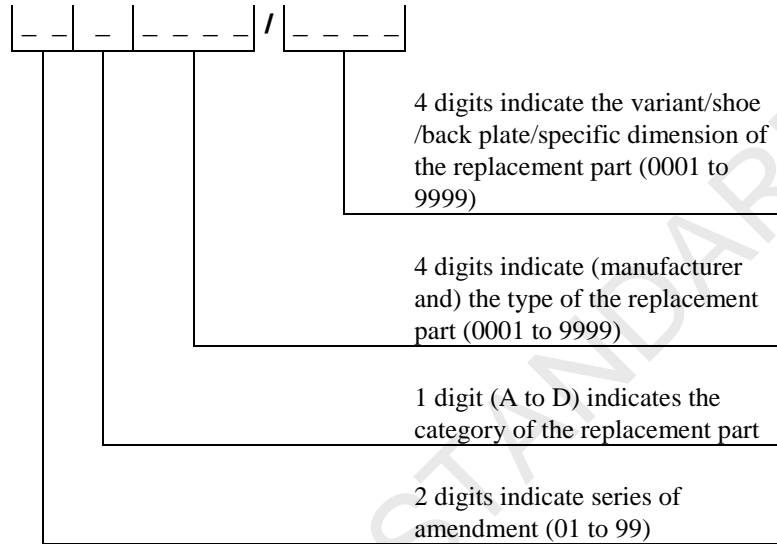

Example:

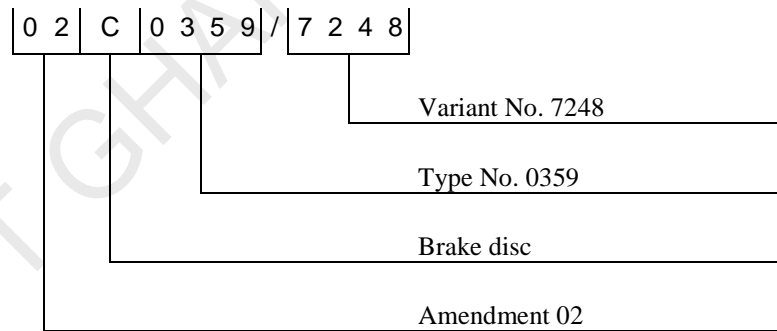

4.3. The same Contracting Party may not assign the same number to another replacement part. The same type approval number may cover the use of that replacement part on a number of differing vehicle types.

4.4. Notice of approval or of extension or refusal of approval or withdrawal of approval or production definitively discontinued of a replacement part pursuant to this Regulation shall be communicated to the Parties to the 1958 Agreement which apply this Regulation by means of a form conforming to the model in Annex 1 to this Regulation.

- 4.5. There shall be affixed, conspicuously and in a readily accessible place, to every replacement part approved under this Regulation, an international approval mark consisting of:
- 4.5.1. A circle surrounding the letter "E" followed by the distinguishing number of the country which has granted approval<sup>3</sup>;
- 4.5.2. The number of this Regulation, followed by the letter "R", a dash and the approval number to the right of the circle prescribed in paragraph 4.5.1.
- 4.6. The approval mark referred to in paragraph 4.5. above shall be clearly legible and be indelible.
- 4.7. Annex 2 to this Regulation gives examples of arrangements of the approval mark and approval data referred to above and in paragraph 6.5. below.

## 5. Specifications and tests

### 5.1. General

A replacement part shall be so designed and constructed that, when substituted for the part originally fitted to a vehicle, the braking efficiency of that vehicle accords with that of the approved vehicle type.

Specifically:

- (a) A replacement part for a vehicle type approved prior to Regulation No. 13, 09 series of amendments, or the original version of Regulation No. 13-H or Regulation No. 78, 01 series of amendments, shall satisfy as a minimum the appropriate above-mentioned Regulation level;
- (b) A replacement part shall display performance characteristics similar to that of the original part it is intended to replace;
- (c) A replacement part must possess adequate mechanical characteristics;
- (d) Brake linings shall not contain asbestos;
- (e) A replacement brake disc/drum shall exhibit sufficient deformation resistance under temperature;
- (f) The minimum thickness of the brake disc shall not be less than the minimum thickness of the original brake disc as specified by the vehicle manufacturer;
- (g) The maximum permissible inside diameter of the brake drum shall not be more than the maximum permissible inside diameter of the original brake drum specified by the vehicle manufacturer.

- 5.1.1. Replacement brake lining assemblies or replacement drum brake linings conforming to the type specified in vehicle type approval documentation to Regulation No. 13 or to Regulation No. 13-H or Regulation No. 78 are deemed to satisfy the requirements of paragraph 5. of this Regulation.

---

<sup>3</sup> The distinguish numbers of the Contracting Parties to the 1958 Agreement are reproduced in Annex 3 to Consolidated Resolution on the Construction of Vehicles (R.E.3), document ECE/TRANS/WP.29/78/Rev.2/Amend.1.



- 5.1.2. Replacement discs and replacement drums conforming to the identification code specified in vehicle type approval documentation to Regulation No. 13 or to Regulation No. 13-H are deemed to satisfy the requirements of paragraph 5. of this Regulation.
- 5.2. Requirements regarding the approval of a replacement brake lining assembly type, a replacement drum brake lining type or a replacement drum brake lining
- 5.2.1. Performance requirements
- 5.2.1.1. Replacement brake lining assemblies for vehicles of categories M<sub>1</sub>, M<sub>2</sub> and N<sub>1</sub>
- At least one set of replacement brake lining assemblies, representing the type of lining to be approved, shall be installed and tested in at least one vehicle which is representative of the vehicle type for which approval is sought, according to the prescriptions of Annex 3 and shall satisfy the requirements stated in this annex. The representative vehicle(s) shall be selected from among the application range using a worst case analysis<sup>4</sup>. For speed sensitivity and cold performance equivalence, one of the two methods described in Annex 3 shall be used.
- 5.2.1.2. Replacement brake lining assemblies and replacement drum brake linings for vehicles of categories M<sub>3</sub>, N<sub>2</sub> and N<sub>3</sub>
- At least one set of replacement brake lining assemblies or replacement drum brake linings, representing the type of lining to be approved, shall be installed and tested in at least one vehicle or a brake which is representative of the vehicle type for which approval is sought, according to the prescriptions of Annex 4, using one of the two methods described in paragraph 1. (vehicle test) or in paragraph 2. (inertia dynamometer test) and shall satisfy the requirements stated in this annex. The representative vehicle(s) or brake(s) shall be selected from among the application range using a worst case analysis<sup>4</sup>.
- 5.2.1.3. Replacement brake lining assemblies for vehicles of categories O<sub>1</sub> and O<sub>2</sub>
- Replacement brake lining assemblies shall be tested according to the prescriptions of Annex 5 and shall satisfy the requirements stated in this annex.
- 5.2.1.4. Replacement brake lining assemblies and replacement drum brake linings for vehicles of categories O<sub>3</sub> and O<sub>4</sub>

---

<sup>4</sup> Worst case analysis must include the following technical characteristics (as a minimum) of each vehicle type in the application range:

- (a) Rotor diameter;
- (b) Rotor thickness;
- (c) Ventilated or solid rotor;
- (d) Piston diameter;
- (e) Tyre dynamic radius;
- (f) Vehicle mass;
- (g) Axle mass and percentage of braking effort of the axle;
- (h) Maximum speed of the vehicle.

The testing conditions shall be specified in the test report.

Replacement brake lining assemblies and replacement drum brake linings shall be tested according to the prescriptions of Annex 6 and shall satisfy the requirements stated in this annex. For the tests, one of the three methods described in paragraph 3. of Appendix 2 to Annex 11 of Regulation No. 13 shall be used.

5.2.1.5. Replacement brake lining assemblies for vehicles of category L

At least one set of replacement brake lining assemblies, representing the type of lining to be approved, shall be installed and tested in at least one vehicle which is representative of the vehicle type for which approval is sought, according to the prescriptions of Annex 7 and shall satisfy the requirements stated in this annex. The representative vehicle(s) shall be selected from among the application range using a worst case analysis<sup>4</sup>.

5.2.2. Mechanical characteristics

5.2.2.1. Replacement brake lining assemblies for vehicles of categories M<sub>1</sub>, M<sub>2</sub>, N<sub>1</sub>, O<sub>1</sub>, O<sub>2</sub>, and L

5.2.2.1.1. Replacement brake lining assemblies of the type for which approval is requested shall be tested for shear strength according to Standard either ISO 6312:1981 or ISO 6312:2001.

The minimum acceptable shear strength is 250 N/cm<sup>2</sup> for pad assemblies and 100 N/cm<sup>2</sup> for shoe assemblies.

5.2.2.1.2. Replacement brake lining assemblies of the type for which approval is requested shall be tested for compressibility according to standard either ISO 6310:1981, ISO 6310:2001 or ISO 6310:2009.

The compressibility values shall not exceed 2 per cent at ambient temperature and 5 per cent at 400 °C for pad assemblies and 2 per cent at ambient temperature and 4 per cent at 200 °C for shoe assemblies. This requirement does not apply to parking brake lining assemblies.

5.2.2.2. Replacement brake lining assemblies and replacement drum brake linings for vehicles of categories M<sub>3</sub>, N<sub>2</sub>, N<sub>3</sub>, O<sub>3</sub>, and O<sub>4</sub>

5.2.2.2.1. Shear strength

This test applies only to disc brake pad assemblies.

Replacement brake lining assemblies of the type for which approval is requested shall be tested for shear strength according to Standard ISO 6312:1981 or ISO 6312:2001. Brake lining assemblies may be divided into two or three parts to match the test machine's capability.

The minimum acceptable shear strength is 250 N/cm<sup>2</sup>.

5.2.2.2.2. Compressibility

Replacement brake lining assemblies and replacement drum brake linings of the type for which approval is requested shall be tested for compressibility according to standard either ISO 6310:1981, ISO 6310:2001 or ISO 6310:2009. Flat specimens according to sample type I may be used.

The compressibility values shall not exceed 2 per cent at ambient temperature and 5 per cent at 400 °C for pad assemblies and 2 per cent at ambient temperature and 4 per cent at 200 °C for shoe assemblies and drum brake linings.

5.2.2.2.3. Material hardness<sup>5</sup>

This requirement applies to drum brake lining assemblies and drum brake linings.

Replacement brake lining assemblies or replacement drum brake linings of the type for which approval is requested shall be tested for hardness according to Standard ISO 2039-2:1987.

The hardness figure for the friction material at the rubbing surface shall be the mean value out of five sample linings from different production batches (if available) by taking five measurements at different places of each brake lining.

5.3. Technical requirements regarding the approval of a replacement brake drum or a replacement brake disc

All replacement parts have to be separated in 4 groups:

- (a) Original replacement brake disc/drum;
- (b) Identical brake disc/drum;
- (c) Equivalent disc/drum;
- (d) Interchangeable disc/drum.

Depending on its group, the replacement brake disc or drum has to pass the following tests:

	<i>Performance tests according to Regulations Nos. 13/13-H (Type 0, I, II, etc.)</i>	<i>Comparison test with dynamic frictional properties of the original part</i>	<i>Integrity tests (high load and thermal fatigue)</i>
Original replacement parts	No	No	No
Identical parts	No	No	No
Equivalent parts	No	No	Dynamometer test
Interchangeable parts	Vehicle test or alternative dynamometer test	Vehicle test or alternative dynamometer test	Dynamometer test

The test requirements for brake discs and drums for vehicles of categories M and N are detailed in Annex 11.

The test requirements for brake discs and drums for vehicles of category O are detailed in Annex 12.

5.3.1. Original replacement brake discs/drums

5.3.1.1. Original replacement brake discs/drums are excluded from the scope of this Regulation provided they carry an identification code as defined in paragraph 2.3.2. affixed in such a way as to be indelible and clearly legible.

<sup>5</sup> This test is included for conformity of production purposes. Minimum values and the tolerances to be agreed with the Technical Service.

5.3.2. Identical brake discs/drums

5.3.2.1. The applicant for approval shall demonstrate to the approval authority that he supplies the brake discs or drums to the vehicle manufacturer as original equipment of the vehicles/axles/brakes mentioned under Annex 1B point 4. In particular, the brake discs or drums shall be produced under the same production and quality assurance systems and conditions as for the original parts pursuant to paragraph 2.3.1.

5.3.2.2. Since the identical brake discs/drums fulfils all requirement as the Original part no testing requirements are prescribed.

5.3.3. Equivalent replacement discs or drums

5.3.3.1. Geometric requirements

The brake discs or drums shall be identical to the original brake disc or drum in respect to all dimensions, geometric features and basic design.

5.3.3.1.1. For discs the following maximum values shall be met:

	$M_1, N_1, O_1, O_2$	$M_2, M_3, N_2, N_3, O_3, O_4$
Thickness variation	0.015 mm	0.030 mm
Cheek thickness variation (for ventilated disc only)	1.5 mm	2.0 mm
Lateral run-out friction surface	0.050 mm*	0.15 mm*
Location bore variation	H9	H9
"Top hat" parallelism	0.100 mm	0.100 mm
Location face flatness	0.050 mm	0.050 mm
Friction surface roughness**	3.2 $\mu$ m	3.2 $\mu$ m

\* n/a in the case of a floating disc.

\*\* Ra-value according to ISO 1302:2002.

5.3.3.1.2. For drums the following maximum values shall be met:

	$M_1, N_1, O_1, O_2$	$M_2, M_3, N_2, N_3, O_3, O_4$
Radial run-out friction surface	0.050 mm	0.100 mm
Location bore variation	H9	H9
Ovality	0.040 mm	0.150 mm
Location face flatness	0.050 mm	0.050 mm
Friction surface roughness*	3.5 $\mu$ m	3.5 $\mu$ m

\* Ra-value according to ISO 1302:2002.

5.3.3.2. Material and metallurgical requirements

In order to be considered "Equivalent" the replacement brake disc or drum shall be from the same material sub-group as the original brake disc or drum. Four original part material sub-groups are defined.

	<i>Test standard</i>	<i>Sub-group 1 Base cast iron DIN EN 1561 EN-GJL-200</i>	<i>Sub-group 2 Base high carbon EN-GJL-150</i>	<i>Sub-group 3 Alloyed high carbon</i>	<i>Sub-group 4 Unalloyed high carbon</i>
Carbon Content (per cent)		3.20-3.60	3.60-3.90	3.55-3.90	3.60-3.90
Silicon Content (per cent)		1.70-2.30	1.60-2.20	1.60-2.20	1.60-2.20
Manganese Content (per cent)		Min 0.40	Min 0.40	Min 0.40	Min 0.40
Chromium Content (per cent)		Max 0.35	Max 0.35	0.30-0.60	Max 0.25
Copper Content (per cent)		–	0.30-0.70	0.30-0.70	Max 0.40
Hardness HBW	ISO 6506-1:2005	190-248	160-210	180-230	160-200
Tensile strength (N/mm <sup>2</sup> )	ISO 6892:1998	Min 220	Min 160	Min 170	Min 150

5.3.3.3. Performance requirements

The part has to pass the integrity tests for high load and thermal fatigue according to Annexes 11 and 12.

5.3.4. Interchangeable replacement discs or drums

5.3.4.1. Geometric requirements

As paragraphs 5.3.3.1.1. and 5.3.3.1.2. plus the same interface dimensions.

An interchangeable replacement disc or drum may differ from the original part disc in design features such as:

- (a) Type and geometry of ventilation (for vented discs);
- (b) Integral or composite disc or drum;
- (c) Surface finish (e.g. holes, slots etc.).

5.3.4.2. Performance requirements

The part has to pass the following performance tests according to Annexes 11 and 12:

- (a) The performance test according to Regulation No. 13 or 13-H;
- (b) The Comparison test with dynamic frictional properties of the original part;
- (c) The integrity tests for high load and thermal fatigue.

5.3.5. Type

Brake discs/drums that do not differ in terms of their main characteristics as detailed below shall be regarded as one type within one report or approval:

5.3.5.1. Type criteria for brake discs

5.3.5.1.1. Basic design

- (a) With or without ventilation (e.g. solid, ventilated);
- (b) Design of ventilation;

- (c) Surface (e.g. with or without grooves or holes);
- (d) Hub (with or without integrated parking brake drum);
- (e) Mounting (rigid, semi-floating, floating, etc.);
- (f) Hat (with or without integrated parking brake drum).

5.3.5.1.2. Material group

All material groups (including their respective sub-groups) are considered to be a separate type.

5.3.5.1.2.1. Cast iron

5.3.5.1.2.2. Steel

5.3.5.1.2.3. Composite materials

5.3.5.1.2.4. Multi-material construction

5.3.5.2. Type criteria for brake drums

- (a) Material group (e.g. steel, cast iron, composite);
- (b) Hub (with/without);
- (c) Composite design.

5.3.6. Test group criteria (within the same type)

The testing in test groups is possible for interchangeable parts only if the connection between the mounting area and the disc friction faces are of the same general form.

From each of the test groups mentioned below, at least one variant is subject to the corresponding tests laid down in Annexes 10, 11 or 12. The variant chosen from within a test group to test the replacement part is that which has the highest ratio of kinetic energy to its directly corresponding replacement part mass:

$$\text{Max} \left( \frac{E_i}{m_{\text{replacement part, i}}} \right) = \text{Max} \left( \frac{0.5 \cdot m \cdot v_{\text{max, i}}^2}{m_{\text{replacement part, i}}} \right)$$

With:

$v_{\text{max, i}}$  maximum design speed of the vehicle to which the replacement part is fitted (in the case of trailers  $v_{\text{max, i}}$  is assumed at least at 80 km/h)

$m$  test mass as defined in Annex 11, paragraph 3.2.1.2. and Annex 12, paragraph 3.2.1.2.

$m_{\text{replacement part, i}}$  mass of the replacement part" of the corresponding vehicle

5.3.6.1. Replacement brake discs

5.3.6.1.1. Criteria concerning the formation of test groups with regard to replacement brake discs in vehicles belonging to categories  $M_1$ ,  $M_2$ ,  $N_1$ ,  $N_2$ ,  $O_1$  and  $O_2$

5.3.6.1.1.1. Test group relating to the tests stipulated in paragraphs 1. to 4. of Annex 11 or Annex 12

This test group includes all brake discs where the outside diameter of the disc do not vary by more than 6 mm and the disc thickness by not more than 4 mm.

- 5.3.6.1.1.2. In the case of different materials within a group of materials, proof shall be furnished for each separate material that the requirements stipulated in Annex 11 or Annex 12 are met.
- 5.3.6.1.2. Criteria concerning the formation of test groups with regard to replacement brake discs in vehicles belonging to categories M<sub>3</sub>, N<sub>3</sub>, O<sub>3</sub> and O<sub>4</sub>
- 5.3.6.1.2.1. Test group relating to the tests stipulated in paragraphs 1. to 4. of Annex 11 or Annex 12
- This test group includes all brake discs where the outside diameter of the disc does not vary by more than 10 mm and the disc thickness by not more than 4 mm.
- 5.3.6.1.2.2. In the case of different materials within a group of materials, proof shall be furnished for each separate material that the requirements stipulated in Annex 11 or Annex 12 are met.
- 5.3.6.2. Replacement brake drums
- 5.3.6.2.1. Criteria concerning the formation of test groups with regard to replacement brake drums in vehicles belonging to categories M<sub>1</sub>, M<sub>2</sub>, N<sub>1</sub>, N<sub>2</sub>, O<sub>1</sub> and O<sub>2</sub>
- 5.3.6.2.1.1. Test group relating to the tests stipulated in paragraphs 1. to 4. of Annex 11 or Annex 12
- This test group includes all brake drums that do not vary by more than 30 mm in terms of the inside diameter of the drum and by more than 10 mm as regards the shoe width of the drum brake.
- 5.3.6.2.1.2. In the case of different materials within a group of materials, proof shall be furnished for each separate material that the requirements stipulated in Annex 11 or Annex 12 are met.
- 5.3.6.2.2. Criteria concerning the formation of test groups with regard to replacement brake drums in vehicles belonging to categories M<sub>3</sub>, N<sub>3</sub>, O<sub>3</sub> and O<sub>4</sub>
- 5.3.6.2.2.1. Test group relating to the tests stipulated in paragraphs 1. to 4. of Annex 11 or Annex 12
- This test group includes all brake drums that do not vary by more than 10 per cent (referring to the smallest value) in terms of the inside diameter of the drum and by more than 40 mm as regards the shoe width of the drum brake.
- 5.3.6.2.2.2. In the case of different materials within a group of materials, proof shall be furnished for each separate material that the requirements stipulated in Annex 11 or Annex 12 are met.
- 5.3.7. Scope of assessment with regard to replacement brake discs/drums
- 5.3.7.1. Geometric checks
- Compared with original parts, replacement brake discs/drums shall be checked in terms of the following applicable characteristics (see also Annex 10):
- (a) Disc/drum diameter, including friction surface diameters (in the case of a disc brake with an integrated parking brake drum, both diameters have to be checked);

- (b) Disc thickness (original dimensions and the minimum permissible wear indication) – mounting face to external friction surface;
- (c) Mounting flange thickness;
- (d) Pitch circle diameter of fixing holes/studs;
- (e) Number of fixing holes/studs;
- (f) Mounting flange diameter;
- (g) Type of centring (e.g. central spigot or mounting bolts/studs);
- (h) In the case of brake discs with integrated parking brake drums the width of the friction surface area and any heat compensation groove(s);
- (i) Additionally, in the case of ventilated brake discs:
  - (i) The type of ventilation (internal/external);
  - (ii) The number of ribs and pillars;
  - (iii) The dimensions of the ventilation duct.

5.3.7.2. Balancing provision

The balancing provision with regard to the replacement brake discs/drums shall correspond to that of the original part being replaced.

5.3.7.3. Assessment of the wear condition of the friction surfaces

This shall conform to the vehicle manufacturer criteria.

5.3.7.4. Tests

Each test group (see 5.3.6.) within a particular type of replacement brake disc/drum (see 3.3.2.) shall be tested by the Technical Service.

5.3.8. Test report

A test report shall be produced, the content of which shall be at least that defined in Annex 13 to this Regulation.

## **6. Packaging and marking**

6.1. Packaging and marking requirements regarding a replacement brake lining assembly type, a replacement drum brake lining type or a replacement drum brake lining:

6.1.1. Replacement brake lining assemblies or replacement drum brake linings conforming to a type approved in accordance with this Regulation shall be marketed in axle sets.

6.1.2. Each axle set shall be contained in a sealed package constructed to show previous opening.

6.1.3. Each package shall display the following information:

6.1.3.1. The quantity of replacement brake lining assemblies or replacement drum brake linings in the package;

6.1.3.2. Manufacturer's name or trade mark;



- 6.1.3.3. Make and type of replacement brake lining assemblies or replacement drum brake linings;
- 6.1.3.4. The vehicles/axles/brakes for which the contents are approved;
- 6.1.3.5. The approval mark.
- 6.1.4. Each package shall contain fitting instructions in an official ECE language, supplemented by the corresponding text in the language of the country where it is sold:
  - 6.1.4.1. With particular reference to auxiliary parts;
  - 6.1.4.2. Stating that replacement brake lining assemblies or replacement drum brake linings should be replaced in axle sets;
  - 6.1.4.3. With, in the case of replacement drum brake linings, a general statement calling attention to the following points:
    - The integrity of the shoe platform, abutment and pivot;
    - Freedom of the shoe from distortion, deformation and corrosion;
    - The type and size of rivet to be used;
    - The required riveting tools and forces.
  - 6.1.4.4. With, additionally, in the case of combined braking systems in the meaning of paragraph 2.9. of Regulation No. 78 giving the approved brake lining assembly combination(s).
- 6.1.5. Each replacement brake lining assembly or replacement drum brake lining shall display permanently one set of approval data:
  - 6.1.5.1. The approval mark;
  - 6.1.5.2. The date of manufacture, at least month and year, or batch number;
  - 6.1.5.3. Make and type of brake lining.
- 6.2. Packaging and marking requirements regarding replacement brake discs or replacement brake drums
  - 6.2.1. Every unit sold shall at least exhibit the following information:
    - 6.2.1.1. Part number;
    - 6.2.1.2. In the case of motor vehicles:
      - Make, type and trade name of the vehicle, the axle intended to be fitted and period of manufacturing of the vehicle; should the period of manufacture not be readily available a reference to the original part number/identification code may be used;
    - 6.2.1.3. In the case of trailers a reference to the original part number/identification code shall be used;
    - 6.2.1.4. Each package shall contain fitting instructions in the language of the country where it is sold:
      - 6.2.1.4.1. With particular reference to ancillary parts;
      - 6.2.1.4.2. Stating that replacement brake discs and drums should be replaced in axle sets.

- 6.2.2. Marking
- Every brake disc/drum approved in accordance with this Regulation shall be durably marked with at least the following information:
- 6.2.2.1. Manufacturer's name or trade mark;
- 6.2.2.2. The approval number;
- 6.2.2.3. An indication which provides traceability of the production process (e.g. date, batch number, source code);
- 6.2.2.4. The minimum thickness of the brake disc or the maximum permissible inside diameter of the brake drum.

## **7. Modifications and extension of approval of replacement parts**

- 7.1. Every modification of the replacement part shall be notified to the Type Approval Authority which granted the type approval. The department may then either:
- 7.1.1. Consider that the modifications made are unlikely to have appreciable adverse effects and that in any event the replacement part still complies with the requirements; or
- 7.1.2. Require a further test report from the technical service responsible for conducting the tests.
- 7.2. Confirmation or refusal of approval, specifying the alterations, shall be notified by the procedure specified in paragraph 4.4. above to the Parties to the 1958 Agreement applying this Regulation.
- 7.3. The Competent Authority issuing the extension of approval shall assign a series number for such an extension and inform thereof the other Parties to the 1958 Agreement applying this Regulation by means of a communication form conforming to the model in Annex 1 to this Regulation.

## **8. Conformity of production**

- 8.1. Replacement parts approved to this Regulation shall be so manufactured as to conform to the type approved.
- 8.2. Original parts being the subject of an application under paragraph 3.2. are deemed to satisfy the requirements of paragraph 8.
- 8.3. To verify that the requirements of paragraph 8.1. are met, suitable controls of the production shall be applied. These shall encompass the control of raw materials and components used.
- 8.4. The holder of an approval shall in particular:
- 8.4.1. Ensure that for each replacement brake lining assembly type or replacement drum brake lining type at least the relevant tests prescribed in paragraph 5.2.2. and the relevant tests as prescribed in Annex 9 to this Regulation are carried out on a statistically controlled and random basis in accordance with a regular quality assurance procedure. For parking brake lining assemblies only the shear strength described in paragraph 5.2.2. is applicable.

- 8.4.2. Ensure that for each replacement disc and drum at least the tests prescribed in Annex 9 to this Regulation are carried out on a statistically controlled and random basis in accordance with a regular quality assurance procedure.
- 8.4.3. Ensure existence of procedures for the effective control of the quality of products;
- 8.4.4. Have access to the control equipment necessary for checking the conformity of each approved type;
- 8.4.5. Analyse the results of each type of test in order to verify and ensure the consistency of the product characteristics, making allowance for variation of an industrial production;
- 8.4.6. Ensure that data of test results are recorded and that annexed documents remain available for a period to be determined in agreement with the administrative service;
- 8.4.7. Ensure that any samples or test pieces giving evidence of non-conformity with the type of test considered shall give rise to another sampling and another test. All the necessary steps shall be taken to re-establish the conformity of the corresponding production.
- 8.5. The Competent Authority which has granted type-approval may at any time verify the conformity control methods applicable to each production unit.
- 8.5.1. In every inspection, the test books and production survey records shall be presented to the visiting inspector.
- 8.5.2. The inspector may take samples at random to be tested in the manufacturer's laboratory. The minimum number of samples may be determined according to the results of the manufacturer's own verification.
- 8.5.3. When the quality level appears unsatisfactory or when it seems necessary to verify the validity of the tests carried out in application of paragraph 8.5.2. the inspector shall select samples to be sent to the technical service which has conducted the type approval tests.
- 8.5.4. The competent authority may carry out any tests prescribed in this Regulation.
- 8.5.5. The normal frequency of inspections authorized by the Competent Authority shall be one per year. In the case where negative results are recorded during one of these visits, the competent authority shall ensure that all necessary steps are taken to re-establish the conformity of production as rapidly as possible.

## **9. Penalties for non-conformity of production**

- 9.1. The approval granted in respect of a replacement brake lining assembly type or drum brake lining type pursuant to this Regulation may be withdrawn if the requirements laid down in paragraph 8.1. above are not complied with.

The approval granted in respect of the type of a replacement brake drum or a replacement brake disc pursuant to this Regulation may be withdrawn if the requirements laid down in paragraph 8.1. above are not complied with.

- 9.2. If a Contracting Party to the Agreement applying this Regulation withdraws an approval it has previously granted, it shall forthwith so notify the other Contracting Parties applying this Regulation, by means of a communication form conforming to the model in Annex 1A or Annex 1B to this Regulation.

## **10. Production definitively discontinued**

If the holder of the approval completely ceases to manufacture a replacement part approved in accordance with this Regulation, he shall so inform the authority which granted the approval. Upon receiving the relevant communication that authority shall inform thereof the other Parties to the 1958 Agreement applying this Regulation by means of a communication form conforming to the model in Annex 1A or 1B to this Regulation.

## **11. Names and addresses of Technical Services responsible for conducting approval tests, and of Type Approval Authorities**

The Contracting Parties to the 1958 Agreement which apply this Regulation shall communicate to the United Nations secretariat the names and addresses of the Technical Services responsible for conducting approval tests and of the Type Approval Authorities which grant approval and to which forms certifying approval or extension or refusal or withdrawal of approval, or production definitively discontinued, issued in other countries, are to be sent.

## **12. Transitional provisions**

- 12.1. As from the official date of entry into force of the 02 series of amendments, no Contracting Party applying this Regulation shall refuse to grant approval under this Regulation as amended by the 02 series of amendments.
- 12.2. Even after the date of entry into force of the 02 series of amendments, brake lining assembly and drum brake lining approvals to the 01 series of amendments to the Regulation shall remain valid and Contracting Parties applying the Regulation shall continue to accept them and shall not refuse to grant extensions of approval to the 01 series of amendments to this Regulation.
- 12.3. Contracting Parties applying this Regulation shall continue to allow fitting or use on a vehicle in use of a replacement brake lining assembly approved to this Regulation in its original, unamended form.

## Annex 1A

### Communication

(Maximum format: A4 (210 x 297 mm))

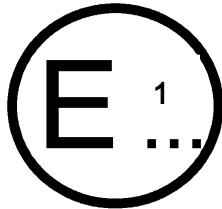

issued by: Name of administration:

.....  
 .....  
 .....

concerning<sup>2</sup>:  
 Approval granted  
 Approval extended  
 Approval refused  
 Approval withdrawn  
 Production definitively discontinued

of a replacement brake lining assembly or replacement drum brake lining pursuant to Regulation No. 90

Approval No..... Extension No.....

1. Applicant's name and address .....
2. Manufacturer's name and address .....
3. Make and type of brake lining assembly/drum brake lining<sup>2</sup> .....
4. Make and type of brake lining.....
5. Vehicles/axles/brakes for which the brake lining assembly type/drum brake lining type qualifies as original brake lining assembly/original drum brake lining: .....
6. Vehicles/axles/brakes for which the brake lining assembly type/drum brake lining type qualifies as replacement brake lining assembly/replacement drum brake lining: .....
- 6.1. Additionally in the case of combined braking systems in the meaning of paragraph 2.9. of Regulation No. 78, approved brake lining assembly combination(s):.....
7. Submitted for approval on.....
8. Technical service responsible for approval tests .....
- 8.1. Date of test report.....
- 8.2. Number of test report .....

<sup>1</sup> Distinguishing number of the country which has granted/extended/refused/withdrawn approval (see approval provisions in the Regulation).

<sup>2</sup> Strike out what does not apply.

9. Approval granted/extended/refused/withdrawn<sup>2</sup>
10. Place .....
11. Date .....
12. Signature .....
13. Annexed to this communication is a list of documents in the approval file deposited at the Type Approval Authorities having delivered the approval and which can be obtained upon request.

DRAFT GHANA STANDARD

## Annex 1B

### Communication

(maximum format: A4 (210 x 297 mm))

issued by: Name of administration:  
.....  
.....  
.....

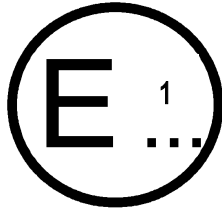

concerning<sup>2</sup>:  
Approval granted  
Approval extended  
Approval refused  
Approval withdrawn  
Production definitively discontinued

of a replacement brake disc or a replacement brake drum pursuant to Regulation No. 90

Approval No..... Extension No.....

1. Applicant name and address .....
2. Manufacturer name and address .....
3. Make and type of brake disc/drum.....
4. Vehicles/axles/brakes for which the replacement brake disc  
or a replacement brake drum is approved:.....
5. Submitted for approval on.....
6. Technical service responsible for approval tests .....
- 6.1. Date of test report.....
- 6.2. Number of test report .....
7. Approval granted/extended/refused/withdrawn<sup>2</sup>
8. Place .....
9. Date .....
10. Signature .....
11. Annexed to this communication is a list of documents in the approval file  
deposited at the Type Approval Authorities having delivered the approval and  
which can be obtained upon request.

<sup>1</sup> Distinguishing number of the country which has granted/extended/refused/withdrawn approval (see approval provisions in the Regulation).

<sup>2</sup> Strike out what does not apply.

## Annex 2

### Arrangements of the approval mark and approval data

(See paragraph 4.2. of this Regulation)

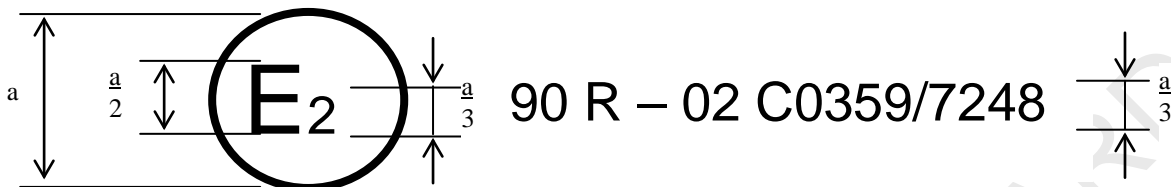

$a = 8 \text{ mm min.}$

The above approval mark shows that the item concerned has been approved in France (E2) pursuant to Regulation No. 90 under approval number C0359/7248. The first two digits of the approval number indicate that the approval was granted in accordance with the requirements of Regulation No. 90 as amended by the 02 series of amendments.



Example of pad assembly marking

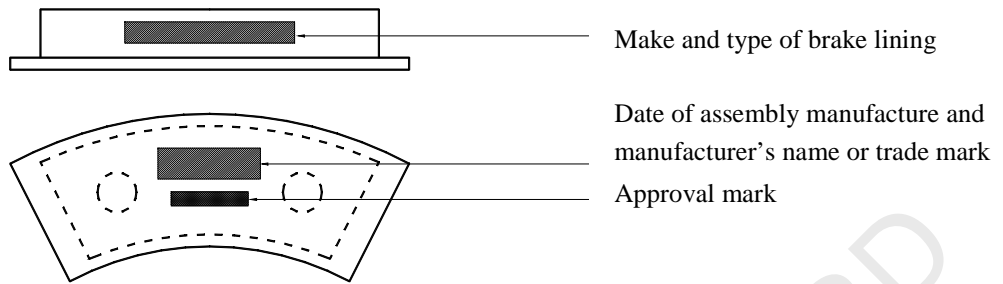

Example of shoe assembly marking

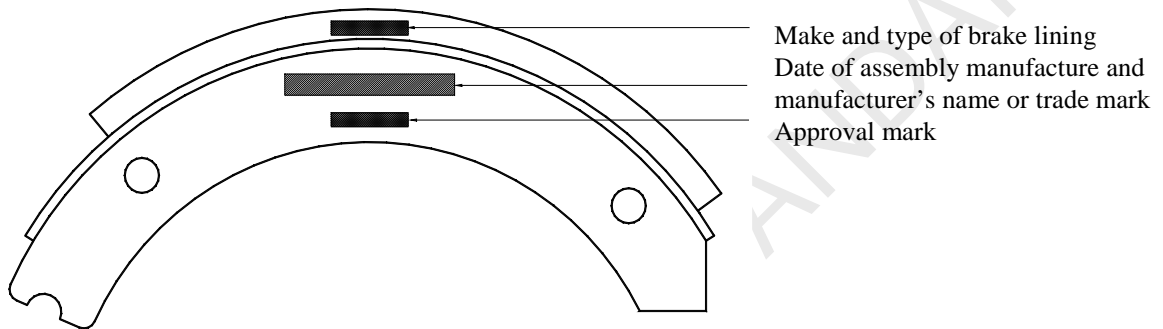

Example of drum brake lining marking

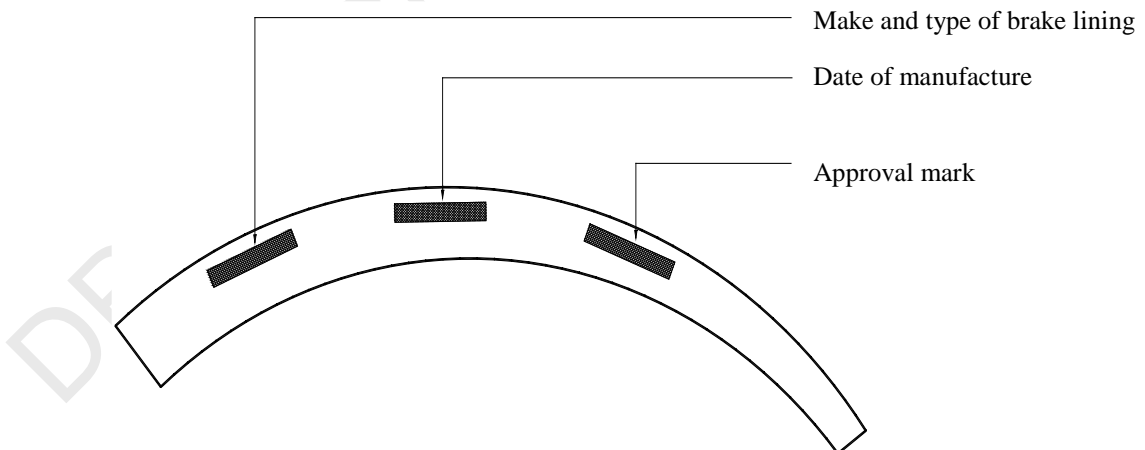

Note: Positions of markings and mutual positions of markings shown in the examples are not mandatory.

## Annex 3

### Requirements for replacement brake lining assemblies for vehicles of categories M<sub>1</sub>, M<sub>2</sub> and N<sub>1</sub>

1. Conformance with Regulation No. 13 or 13-H

Compliance with the requirements of Regulation No. 13 or 13-H shall be demonstrated in a vehicle test.
- 1.1. Vehicle preparation
  - 1.1.1. Test Vehicle

A vehicle which is representative of the type(s) for which the replacement brake lining assembly approval is required shall be equipped with the replacement brake lining assemblies of the type for which approval is requested and instrumented for brake testing as required by Regulations Nos. 13 and 13-H.

Brake linings submitted for test shall be fitted to the relevant brakes and, until a fixed burnishing procedure is established, shall be burnished to the manufacturer's instructions in agreement with the technical service.
  - 1.1.2. Bedding (burnishing) procedure
    - 1.1.2.1. General conditions

Brake lining assemblies submitted for test shall be fitted to the relevant brakes. In the case of replacement brake lining assemblies, new brake linings must be used. Drum brake linings may be machined to achieve the best possible initial contact between the linings and drum(s). The test vehicle shall be fully laden.

Original brake lining assemblies used for comparison test and already fitted to the test vehicle may be used provided they are in a good condition and have not been worn out by more than 20 per cent of the initial thickness. They must not show damages, cracks, excessive corrosion or signs of overheating. They shall be bedded to the procedure described below.
    - 1.1.2.2. Procedure

Perform a minimum 50 km driving distance and at least 100 brake applications at varying decelerations (at least between 1 m/s<sup>2</sup> and 5 m/s<sup>2</sup>) with initial speeds between 50 km/h and 120 km/h. A temperature range between 250 °C and 500 °C for pad assemblies or between 150 °C and 250 °C for drum brake lining assemblies (measured at the rubbing surface of the disc or drum) must be achieved at least 3 times during the bedding procedure. Temperatures must not exceed 500 °C for pad assemblies and 250 °C for drum brake lining assemblies.
    - 1.1.2.3. Performance check

By braking only one axle at a time perform 5 brake applications from 70 km/h to 0 km/h (front axle) and 45 km/h to 0 km/h (rear axle) at a

line pressure of 4 Mpa<sup>1</sup> and with an initial temperature of 100 °C for each stop. The 5 consecutive non-monotonic results must remain within the tolerance of 0.6 m/s<sup>2</sup> (front axle) or 0.4 m/s<sup>2</sup> (rear axle) of their mean fully developed deceleration.

If this requirement is not fulfilled the bedding procedure according to paragraph 1.1.2.2. must be extended and the performance check according to paragraph 1.1.2.3. must be repeated.

- 1.2. The braking system of the vehicle shall be tested according to the requirements for the vehicle category in question (M<sub>1</sub>, M<sub>2</sub> or N<sub>1</sub>) in Regulation No. 13, Annex 4, paragraphs 1. and 2. or Regulation No. 13-H, Annex 3, paragraphs 1. and 2. which ever is appropriate taking into consideration the original approval of the system. The applicable requirements or tests are:
  - 1.2.1. Service braking system
    - 1.2.1.1. Type-0 test with engine disconnected, vehicle laden, according to Regulation No. 13, Annex 4, paragraph 1.4.2. or Regulation No. 13-H, Annex 3, paragraph 1.4.2.
    - 1.2.1.2. Type-0 test with engine connected, vehicle unladen and laden, according to Regulation No. 13, Annex 4, paragraphs 1.4.3.1. (stability test) and 1.4.3.2. (only the test with initial speed  $v = 0.8 v_{max}$ ) or Regulation No. 13-H, Annex 3, paragraphs 1.4.3.1. and 1.4.3.2.
    - 1.2.1.3. Type-I test, according to Regulation No. 13, Annex 4, paragraph 1.5. or Regulation No. 13-H, Annex 3, paragraph 1.5.
  - 1.2.2. Secondary braking system
    - 1.2.2.1. Type-0 test with engine disconnected, vehicle laden, according to Regulation No. 13, Annex 4, paragraph 2.2. or Regulation No. 13-H, Annex 3, paragraph 2.2. (this test may be omitted in cases where it is obvious that the requirements are met, e.g. diagonal split braking system).
  - 1.2.3. Parking braking system

(Only applicable if the brakes for which lining approval is sought are used for parking).

    - 1.2.3.1. Parking brake test at 18 per cent gradient, vehicle laden, according to Regulation No. 13, Annex 4, paragraph 2.3.1. or parking brake test at 20 per cent gradient, vehicle laden, Regulation No. 13-H, Annex 3, paragraph 2.3.1.
- 1.3. The vehicle must satisfy all the relevant requirements stated in Regulation No. 13, Annex 4, paragraph 2. or Regulation No. 13-H, Annex 3, paragraph 2. for that category of vehicle.
2. Additional requirements

Compliance with the additional requirements shall be demonstrated by using one of the two following methods:

---

<sup>1</sup> For other than hydraulic braking systems an equivalent input value should be used.

2.1. Vehicle test (split axle test)

For this test the vehicle shall be fully laden and all brake applications made with engine disconnected, on a level road.

The vehicle service brake control system shall be equipped with a means of isolating front and rear axle brakes so that either may be used independently of the other.

Where brake lining assembly approval is required for front axle brakes the rear axle brakes shall remain inoperative throughout the test.

Where brake lining assembly approval is required for rear axle brakes the front axle brakes shall remain inoperative throughout the test.

2.1.1. Cold performance equivalence test

A comparison of the cold performance of the replacement brake lining assembly and the original brake lining assembly shall be made by comparing the results of testing to the following method:

- 2.1.1.1. Make a minimum of six brake applications at spaced increments of pedal effort or line pressure up to wheel lock or, alternatively, up to a mean fully developed deceleration of  $6 \text{ m/s}^2$  or up to the allowed maximum pedal force for the category of vehicle in question from an initial speed as given in the table below:

Vehicle category	Test speed in km/h	
	Front axle	Rear axle
M <sub>1</sub>	70	45
M <sub>2</sub>	50	40
N <sub>1</sub>	65	50

The initial brake temperature at the start of each application shall be  $\leq 100 \text{ }^\circ\text{C}$ .

- 2.1.1.2. Note and plot pedal force or line pressure and mean fully developed deceleration for each application, and determine the pedal force or line pressure required to achieve (if possible) a mean fully developed deceleration of  $5 \text{ m/s}^2$  for front axle brakes and  $3 \text{ m/s}^2$  for rear axle brakes. If these values cannot be achieved with the maximum allowed pedal force determine alternatively the pedal force or line pressure required to achieve maximum deceleration.

- 2.1.1.3. The replacement brake lining assembly shall be considered to show similar performance characteristics to the original brake lining assembly if the achieved mean fully developed decelerations at the same control force or line pressure in the upper two thirds of the generated curve are within 15 per cent of those obtained with the original brake lining assembly.

2.1.2. Speed sensitivity test

- 2.1.2.1. Using the pedal force derived from paragraph 2.1.1.2. of this annex and with initial brake temperature  $\leq 100 \text{ }^\circ\text{C}$ , make three brake applications from each of the following speeds:

- (a) Front axle 65, 100 km/h and additionally 135 km/h where  $v_{\text{max}}$  exceeds 150 km/h.
- (b) Rear axle 45, 65 km/h and additionally 90 km/h where  $v_{\text{max}}$  exceeds 150 km/h.

2.1.2.2. Average the results for each group of three applications and plot speed against corresponding mean fully developed deceleration.

2.1.2.3. Mean fully developed decelerations recorded for the higher speeds shall lie within 15 per cent of that recorded for the lowest speed.

2.2. Inertia dynamometer test

2.2.1. Test equipment

For the tests an inertia dynamometer shall be equipped with the vehicle brake in question. The dynamometer shall be instrumented for continuous recording of rotational speed, brake torque, pressure in the brake line, number of rotations after brake application, braking time and brake rotor temperature.

2.2.2. Test conditions

2.2.2.1. The rotational mass of the dynamometer shall correspond to half the axle portion of the maximum vehicle mass as listed in the table below and to the rolling radius of the largest tyre that is authorized for that vehicle type(s).

Vehicle category	Axle portion of maximum vehicle mass	
	Front	Rear
M <sub>1</sub>	0.77	0.32
M <sub>2</sub>	0.69	0.44
N <sub>1</sub>	0.66	0.39

2.2.2.2. The initial dynamometer rotational speed shall correspond to the linear vehicle speed as stated in paragraphs 2.2.3. and 2.2.4. of this annex and shall be based on the dynamic rolling radius of the tyre.

2.2.2.3. Brake linings submitted for test shall be fitted to the relevant brakes and bedded (burnished) according to the following procedure:

Burnishing phase 1, 64 snubs from 80 km/h to 30 km/h at varying line pressures:

Parameter	Front axle	Rear axle	
		Disc brake	Drum brake
Number of snubs per cycle	32	32	32
Brake speed (km/h)	80	80	80
Release speed (km/h)	30	30	30
Initial brake temperature (°C)	< 100	< 100	< 80
Final brake temperature (°C)	Open	Open	Open
Pressure snub 1 (kPa)	1 500	1 500	1 500
Pressure snub 2 (kPa)	3 000	3 000	3 000
Pressure snub 3 (kPa)	1 500	1 500	1 500
Pressure snub 4 (kPa)	1 800	1 800	1 800
Pressure snub 5 (kPa)	2 200	2 200	2 200
Pressure snub 6 (kPa)	3 800	3 800	3 800
Pressure snub 7 (kPa)	1 500	1 500	1 500
Pressure snub 8 (kPa)	2 600	2 600	2 600
Pressure snub 9 (kPa)	1 800	1 800	1 800
Pressure snub 10 (kPa)	3 400	3 400	3 400

<i>Parameter</i>	<i>Rear axle</i>		<i>Rear axle</i>
	<i>Front axle</i>	<i>Disc brake</i>	<i>Drum brake</i>
Pressure snub 11 (kPa)	1 500	1 500	1 500
Pressure snub 12 (kPa)	2 600	2 600	2 600
Pressure snub 13 (kPa)	1 500	1 500	1 500
Pressure snub 14 (kPa)	2 200	2 200	2 200
Pressure snub 15 (kPa)	3 000	3 000	3 000
Pressure snub 16 (kPa)	4 600	4 600	4 600
Pressure snub 17 (kPa)	2 600	2 600	2 600
Pressure snub 18 (kPa)	5 100	5 100	5 100
Pressure snub 19 (kPa)	2 200	2 200	2 200
Pressure snub 20 (kPa)	1 800	1 800	1 800
Pressure snub 21 (kPa)	4 200	4 200	4 200
Pressure snub 22 (kPa)	1 500	1 500	1 500
Pressure snub 23 (kPa)	1 800	1 800	1 800
Pressure snub 24 (kPa)	4 600	4 600	4 600
Pressure snub 25 (kPa)	2 600	2 600	2 600
Pressure snub 26 (kPa)	1 500	1 500	1 500
Pressure snub 27 (kPa)	3 400	3 400	3 400
Pressure snub 28 (kPa)	2 200	2 200	2 200
Pressure snub 29 (kPa)	1 800	1 800	1 800
Pressure snub 30 (kPa)	3 000	3 000	3 000
Pressure snub 31 (kPa)	1 800	1 800	1 800
Pressure snub 32 (kPa)	3 800	3 800	3 800
Number of cycles	2	2	2

Burnishing phase 2, 10 stops from 100 km/h to 5 km/h at 0.4 g deceleration and increasing initial temperatures:

<i>Parameter</i>	<i>Rear axle</i>		<i>Rear axle</i>
	<i>Front axle</i>	<i>Disc brake</i>	<i>Drum brake</i>
Number of stops per cycle	10	10	10
Brake speed (km/h)	100	100	100
Release speed (km/h)	< 5	< 5	< 5
Deceleration level (g)	0.4	0.4	0.4
Maximum pressure (kPa)	16 000	16 000	10 000
Initial temperature 1 (°C)	< 100	< 100	< 100
Initial temperature 2 (°C)	< 215	< 215	< 151
Initial temperature 3 (°C)	< 283	< 283	< 181
Initial temperature 4 (°C)	< 330	< 330	< 202
Initial temperature 5 (°C)	< 367	< 367	< 219
Initial temperature 6 (°C)	< 398	< 398	< 232
Initial temperature 7 (°C)	< 423	< 423	< 244

		<i>Rear axle</i>	<i>Rear axle</i>
<i>Parameter</i>	<i>Front axle</i>	<i>Disc brake</i>	<i>Drum brake</i>
Initial temperature 8 (°C)	< 446	< 446	< 254
Initial temperature 9 (°C)	< 465	< 465	< 262
Initial temperature 10 (°C)	< 483	< 483	< 270
Number of cycles	1	1	1

Recovery, 18 snubs from 80 km/h to 30 km/h at line pressure of 3 000 kPa:

		<i>Rear axle</i>	<i>Rear axle</i>
<i>Parameter</i>	<i>Front axle</i>	<i>Disc brake</i>	<i>Drum brake</i>
Number of stops per cycle	18	18	18
Brake speed (km/h)	80	80	80
Release speed (km/h)	30	30	30
Pressure (kPa)	3 000	3 000	3 000
Initial brake temperature (°C)	< 100	< 100	< 80
Final brake temperature (°C)	Open	Open	Open
Number of cycles	1	1	1

2.2.2.4. Perform 5 brake applications from 80 km/h to 0 km/h at a line pressure of 4 MPa and with an initial temperature of 100 °C for each stop. The 5 consecutive non-monotonic results must remain within the tolerance of 0.6 m/s<sup>2</sup> of their mean fully developed deceleration.

If this requirement is not fulfilled the first part of the bedding procedure "Burnishing Phase 1" must be repeated until the required performance stability is achieved.

2.2.2.5. The use of cooling air is permitted. The speed of the airflow during the brake application at the brake shall be:

$$v_{\text{air}} = 0.33 v$$

Where:

v = vehicle test speed at initiation of braking.

2.2.3. Cold performance equivalence test

A comparison of the cold performance of the replacement brake lining assembly and the original brake lining assembly shall be made by comparing the results of testing to the following method.

2.2.3.1. From the initial speed of 80 km/h for M<sub>1</sub> and N<sub>1</sub> and 60 km/h for M<sub>2</sub> and with brake temperature ≤ 100 °C at the start of each application make a minimum of six brake applications at spaced intervals of line pressure up to a mean fully developed deceleration of 6 m/s<sup>2</sup>.

2.2.3.2. Note and plot line pressure and mean fully developed deceleration for each application, and determine line pressure required to achieve 5 m/s<sup>2</sup>.

- 2.2.3.3. The replacement brake lining assembly shall be considered to show similar performance characteristics to the original brake lining assembly if the achieved mean fully developed decelerations at the same control force or line pressure in the upper two thirds of the generated curve are within 15 per cent of those obtained with the original brake lining assembly.
- 2.2.4. Speed sensitivity test
- 2.2.4.1. Using the line pressure derived from paragraph 2.2.3.2. and with initial brake temperature  $\leq 100$  °C make three brake applications from rotational speeds corresponding to vehicle linear speeds of:  
75, 120 km/h and additionally 160 km/h where  $v_{\max}$  exceeds 150 km/h.
- 2.2.4.2. Average the results for each group of three applications and plot speed against corresponding mean fully developed deceleration.
- 2.2.4.3. Mean fully developed decelerations recorded for the higher speeds shall lie within 15 per cent of that recorded for the lowest speed.

DRAFT GHANA STANDARD



## Annex 4

### Requirements for replacement brake lining assemblies and drum brake linings for vehicles of categories M<sub>3</sub>, N<sub>2</sub> and N<sub>3</sub>

1. Vehicle test
  - 1.1. Test vehicle

A vehicle which is representative of the type(s) for which the replacement brake lining assembly approval or drum brake lining approval is required shall be equipped with brake lining assemblies or drum brake linings of the type for which approval is sought and instrumented for brake testing as required by Regulation No. 13.

Brake linings submitted for test shall be fitted to the relevant brakes and, until a fixed burnishing procedure is established, shall be burnished to the manufacturer's instructions in agreement with the technical service.
  - 1.2. Tests and requirements
    - 1.2.1. Conformance with Regulation No. 13
      - 1.2.1.1. The braking system of the vehicle shall be tested according to the requirements for the vehicle category in question (M<sub>3</sub>, N<sub>2</sub> or N<sub>3</sub>) in Regulation No. 13, Annex 4, paragraphs 1. and 2. The applicable requirements or tests are:
        - 1.2.1.1.1. Service braking system
          - 1.2.1.1.1.1. Type-0 test with engine disconnected, vehicle laden
          - 1.2.1.1.1.2. Type-0 test with engine connected, vehicle unladen and laden, according to Regulation No. 13, Annex 4, paragraphs 1.4.3.1. (stability test) and 1.4.3.2. (only the test with initial speed  $v = 0.8 v_{\max}$ ).
          - 1.2.1.1.1.3. Type-I test according to Regulation No. 13, Annex 4, paragraphs 1.5.1. and 1.5.3.
          - 1.2.1.1.1.4. Type-II test

The laden vehicle must be tested in such a manner that the energy input is equivalent to that recorded in the same period of time with the laden vehicle driven at an average speed of 30 km/h on a 2.5 per cent down-gradient for a distance of 6 km with the gear disengaged, the braking energy being taken by the service brakes alone.
        - 1.2.1.1.2. Secondary braking system
          - 1.2.1.1.2.1. Type-0 test with engine disconnected, vehicle laden (this test may be omitted if covered by tests according to paragraph 1.2.2. of this annex).
        - 1.2.1.1.3. Parking braking system

(Only applicable if the brakes for which lining approval is sought are used for parking.)

          - 1.2.1.1.3.1. Downhill test at 18 per cent gradient, vehicle laden

- 1.2.1.2. The vehicle must satisfy all relevant requirements stated in Regulation No. 13, Annex 4, paragraph 2. for that category of vehicle.
- 1.2.2. Additional requirements (split axle test)
- For the tests mentioned below the vehicle shall be fully laden and all brake applications made with engine disconnected, on a level road.
- The vehicle service brake control system shall be equipped with a means of isolating front and rear axle brakes so that either may be used independently of the other.
- Where brake lining assembly approval or drum brake lining approval is required for front axle brakes the rear axle brakes shall remain inoperative throughout the test.
- Where brake lining assembly approval or drum brake lining approval is required for rear axle brakes the front axle brakes shall remain inoperative throughout the test.
- 1.2.2.1. Cold performance equivalence test
- A comparison of the cold performance of the replacement brake lining assembly or the replacement drum brake lining and the original brake lining assembly or the original drum brake lining shall be made by comparing the results of testing to the following method.
- 1.2.2.1.1. Make a minimum of six brake applications at spaced increments of pedal force or line pressure up to wheel lock or, alternatively, up to a mean fully developed deceleration of  $3.5 \text{ m/s}^2$  or up to the maximum allowed pedal force or up to the maximum line pressure from an initial speed of 45 km/h and with a brake temperature  $\leq 100 \text{ }^\circ\text{C}$  at the start of each application.
- 1.2.2.1.2. Note and plot pedal force or line pressure and mean fully developed deceleration for each application, and determine the pedal force or line pressure required to achieve (if possible) a mean fully developed deceleration of  $3 \text{ m/s}^2$ . If this value cannot be achieved determine alternatively the pedal force or line pressure required to achieve maximum deceleration.
- 1.2.2.1.3. The replacement brake lining assembly or the replacement drum brake lining shall be considered to show similar performance characteristics to the original brake lining assembly or the original drum brake lining if the achieved mean fully developed decelerations at the same control force or line pressure in the upper two thirds of the generated curve are within 15 per cent of those obtained with the original brake lining assembly or the original drum brake lining.
- 1.2.2.2. Speed sensitivity test
- 1.2.2.2.1. Using the pedal force derived from paragraph 1.2.2.1.2. of this annex and with initial brake temperature  $\leq 100 \text{ }^\circ\text{C}$ , make three brake applications from each of the following speeds:
- 40 km/h down to 20 km/h,  
60 km/h down to 40 km/h and  
80 km/h down to 60 km/h (if  $v_{\text{max}} \geq 90 \text{ km/h}$ ).
- 1.2.2.2.2. Average the results for each group of three applications and plot speed against corresponding mean fully developed deceleration.

- 1.2.2.2.3. Mean fully developed decelerations recorded for the higher speeds shall lie within 25 per cent of that recorded for the lowest speed.
2. Inertia dynamometer test
- 2.1. Test equipment
- For the tests an inertia dynamometer shall be equipped with the vehicle brake in question. The dynamometer shall be instrumented for continuous recording of rotational speed, brake torque, pressure in the brake line, number of rotations after brake application, braking time and brake rotor temperature.
- 2.1.1. Test conditions
- 2.1.1.1. The rotational mass of the dynamometer shall correspond to half the axle portion of 0.55 of the maximum vehicle mass and the rolling radius of the largest tyre that is authorised for that vehicle type(s).
- 2.1.1.2. The initial dynamometer rotational speed shall correspond to the linear vehicle speed as stated in the paragraphs below and shall be based on the mean of the dynamic rolling radii of the largest and smallest tyres authorized for that vehicle type(s).
- 2.1.1.3. Brake lining assemblies or drum brake linings submitted for the test shall be fitted to the brake and, until a fixed burnishing procedure is established, shall be burnished to the manufacturer's instructions in agreement with the technical service.
- 2.1.1.4. If cooling air is used, the speed of the airflow at the brake shall be:
- $$v_{\text{air}} = 0.33v$$
- Where:
- $v$  = vehicle test speed at initiation of braking.
- 2.1.1.5. The actuation cylinder fitted to the brake must be of the smallest size that is authorized for that vehicle type(s).
- 2.2. Tests and requirements
- 2.2.1. Tests derived from Regulation No. 13
- 2.2.1.1. Type-0 test
- From the initial speed of 60 km/h with a brake temperature  $\leq 100$  °C at the start of each application make a minimum of six brake applications at spaced intervals of line pressure up to the line pressure that is permanently guaranteed by the braking system of the vehicle type(s) (e.g. cut in pressure of the compressor). A mean fully developed deceleration of at least 5 m/s<sup>2</sup> must be achieved.
- 2.2.1.2. Type-0 test, high speed performance
- Make three brake applications with a brake temperature of  $\leq 100$  °C at the start of each application from a speed of 100 km/h where approval is directed to vehicles of category N<sub>2</sub> and 90 km/h where approval is directed to vehicles of categories M<sub>3</sub> and N<sub>3</sub> using the guaranteed line pressure as defined in paragraph 2.2.1.1. The mean value of the achieved mean fully developed decelerations of the three applications must be at least 4 m/s<sup>2</sup>.

- 2.2.1.3. Type-I test
- 2.2.1.3.1. Heating procedure
- Make 20 consecutive snub applications with  $v_1 = 60$  km/h and  $v_2 = 30$  km/h with a cycle time of 60 s starting at a brake temperature of  $\leq 100$  °C at the first application. The line pressure shall correspond to a deceleration of  $3 \text{ m/s}^2$  at the first application and must remain constant throughout the succeeding applications.
- 2.2.1.3.2. Hot performance
- On completion of the heating procedure the hot performance shall be measured under the conditions of paragraph 2.2.1.1. above using the guaranteed line pressure as defined in paragraph 2.2.1.1. (the temperature conditions may be different). The mean fully developed deceleration with the heated brake must not be less than 60 per cent of the value achieved with the cold brake or  $4 \text{ m/s}^2$ .
- 2.2.1.3.3. Recovery
- Starting 120 s after the hot performance brake application make 5 full stops with the line pressure used in paragraph 2.2.1.3.1. above and with intervals of at least 2 minutes from the initial speed of 60 km/h. At the beginning of the fifth application the brake temperature shall be  $\leq 100$  °C and the mean fully developed deceleration achieved shall be within 10 per cent of that calculated from the relation line pressure/deceleration of the Type-0 test at 60 km/h.
- 2.2.1.4. Type-II test
- 2.2.1.4.1. Heating procedure
- The brakes shall be heated by constant braking torque corresponding to a deceleration of  $0.15 \text{ m/s}^2$  at a constant speed of 30 km/h during a period of 12 minutes.
- 2.2.1.4.2. Hot performance
- On completion of the heating procedure the hot performance shall be measured under the conditions of paragraph 2.2.1.1. above using the guaranteed line pressure as defined in paragraph 2.2.1.1. (the temperature conditions may be different). The mean fully developed deceleration with the heated brake must not be less than  $3.75 \text{ m/s}^2$ .
- 2.2.1.5. Static test for parking performance
- 2.2.1.5.1. For the whole range of applications determine the worst case regarding input force to the brake, maximum vehicle mass to be braked by one axle, and tyre radius.
- 2.2.1.5.2. Apply the brake with the input force as determined under paragraph 2.2.1.5.1. above.
- 2.2.1.5.3. Put a slowly increasing torque on the dynamometer shaft in order to turn the drum or disc. Measure the output torque at the brake in the moment the dynamometer shaft begins to move and calculate corresponding axle braking force using the tyre radius as determined under paragraph 2.2.1.5.1.
- 2.2.1.5.4. The brake force measured under paragraph 2.2.1.5.3. divided by one-half of the vehicle mass as determined under paragraph 2.2.1.5.1. must give at least a quotient of 0.18.

- 2.2.2. Cold performance equivalence test
- A comparison of the cold performance of the replacement brake lining assembly or the replacement drum brake lining and the original brake lining assembly or the original drum brake lining shall be made by comparing the results of the Type-0 test as described in paragraph 2.2.1.1.
- 2.2.2.1. The Type-0 test as prescribed in paragraph 2.2.1.1. shall be performed with one set of the original brake lining assembly or the original drum brake lining.
- 2.2.2.2. The replacement brake lining assembly or the replacement drum brake lining shall be considered to show similar performance characteristics to the original brake lining assembly or the original drum brake lining if the achieved mean fully developed decelerations at the same line pressure in the upper two thirds of the generated curve are within 15 per cent of those obtained with the original brake lining assembly or the original drum brake lining.
- 2.2.3. Speed sensitivity test
- 2.2.3.1. Using the guaranteed line pressure as defined in paragraph 2.2.1.1. and with initial brake temperature  $\leq 100$  °C, make three brake applications from each of the following speeds:
- 60 km/h down to 30 km/h,  
80 km/h down to 60 km/h, and  
110 km/h down to 80 km/h (if  $v_{\max} \geq 90$  km/h).
- 2.2.3.2. Average the results for each group of three applications and plot speed against corresponding mean fully developed deceleration.
- 2.2.3.3. Mean fully developed decelerations recorded for the higher speeds shall lie within 25 per cent of that recorded for the lowest speed.

## Annex 5

### Requirements for replacement brake lining assemblies for vehicles of categories O<sub>1</sub> and O<sub>2</sub>

1. General

The test method described in this annex is based on an inertia dynamometer test. Alternatively the tests may be carried out on a test vehicle or on a rolling road test bench provided that the same test conditions are achieved and the same parameters measured as in the inertia dynamometer test.

2. Test equipment

For the tests an inertia dynamometer shall be equipped with the vehicle brake in question. The dynamometer shall be instrumented for continuous recording of rotational speed, brake torque, pressure in the brake line or actuation force, number of rotations after brake application, braking time and brake rotor temperature.

2.1. Test conditions

2.1.1. The rotational mass of the dynamometer shall correspond to half the relevant axle portion of the maximum vehicle mass and the rolling radius of the largest tyre that is authorized for that vehicle type(s).

2.1.2. The initial dynamometer rotational speed shall correspond to the linear vehicle speed as stated in paragraph 3.1. of this annex and shall be based on the dynamic rolling radius of the smallest tyre that is authorized for that vehicle type(s).

2.1.3. Brake linings submitted for the test shall be fitted to the relevant brake and, until a fixed burnishing procedure is established, shall be burnished to the manufacturer's instructions in agreement with the technical service.

2.1.4. If cooling air is used, the speed of the airflow at the brake shall be:

$$v_{\text{air}} = 0.33v$$

Where:

v = vehicle test speed at initiation of braking.

2.1.5. The actuation device fitted to the brake must correspond to the vehicle installation.

3. Tests and requirements

3.1. Type-0 test

From the initial speed of 60 km/h with a brake temperature  $\leq 100$  °C at the start of each application make a minimum of six consecutive brake applications at spaced intervals of line pressure or application force up to the maximum line pressure or up to  $6 \text{ m/s}^2$  deceleration. Repeat the last brake application using an initial speed of 40 km/h.

- 3.2. Type-I test
  - 3.2.1. Heating procedure

The brake shall be heated with continuous braking according to the requirement of Regulation No. 13, Annex 4, paragraph 1.5.2. starting with a brake rotor temperature  $\leq 100$  °C.
  - 3.2.2. Hot performance

On completion of the heating procedure the hot performance from an initial speed of 40 km/h shall be measured under the conditions of paragraph 3.2.1. above using the same line pressure or application force (the temperature conditions may be different). The mean fully developed deceleration with the heated brake must not be less than 60 per cent of the value achieved with the cold brake or 3.5 m/s<sup>2</sup>.
- 3.3. Cold performance equivalence test

A comparison of the cold performance of the replacement brake lining assembly and the original brake lining assembly shall be made by comparing the results of the Type-0 test as described in paragraph 3.1.

  - 3.3.1. The Type-0 test as prescribed in paragraph 3.1. shall be performed with one set of the original brake lining assembly.
  - 3.3.2. The replacement brake lining assembly shall be considered to show similar performance characteristics to the original brake lining assembly if the achieved mean fully developed decelerations at the same line pressure or application force in the upper two thirds of the generated curve are within 15 per cent of those obtained with the original brake lining assembly.

## Annex 6

### Requirements for replacement brake lining assemblies and drum brake linings for vehicles of categories O<sub>3</sub> and O<sub>4</sub>

1. Test conditions

The tests prescribed in this annex may be carried out alternatively on a test vehicle or on an inertia dynamometer or on a rolling road test bench under the same conditions as mentioned in Regulation 13, Annex 11, Appendix 2, paragraphs 3.1. to 3.4.

Brake linings submitted for test shall be fitted to the relevant brakes and, until a fixed burnishing procedure is established, shall be burnished to the manufacturer's instructions in agreement with the technical service.
2. Tests and requirements
  - 2.1. Conformance with Regulation No. 13, Annex 11

The brakes shall be tested according to the requirements of Regulation No. 13, Annex 11, Appendix 2, paragraph 3.5.
  - 2.1.1. The results shall be reported in a form according to Regulation No. 13, Annex 11, Appendix 3.
  - 2.1.2. A comparison shall be made between these results and those obtained with the original brake lining assemblies or the original drum brake linings under the same conditions.
  - 2.1.3. The achieved hot performance at the same input torque of the replacement brake lining assembly or the replacement drum brake lining in the Type-I test or in the Type-III test (whichever is applicable) must be:
    - (a) Equal to or higher than the hot performance of the original brake lining assembly or the original drum brake lining, or
    - (b) At least 90 per cent of the cold performance of the replacement brake lining assembly or the replacement drum brake lining.

The corresponding stroke of the actuator must not be  $\geq 110$  per cent of the value achieved with the original brake lining assembly or the original drum brake lining and must not exceed the value  $s_p$  as defined in Annex 11, Appendix 2, paragraph 2. of Regulation No. 13. In the case where the original brake lining assembly or drum brake lining has been tested against the Type-II test requirements, the minimum requirements of Regulation No. 13, Annex 4, paragraph 1.7.2. (Type-III test) are applicable for the replacement brake lining assembly or drum brake lining.
  - 2.2. Cold performance equivalence test (Type-0)
    - 2.2.1. Under the conditions of paragraph 1 of this annex and from an initial speed of 60 km/h with a brake temperature  $\leq 100$  °C make 6 brake applications at spaced intervals of control force or line pressure up to 6.5 bar or an achieved deceleration of 6 m/s<sup>2</sup>.



- 2.2.2. Note and plot control force or line pressure and mean brake torque or mean fully developed deceleration for each application.
- 2.2.3. Compare the results with those obtained with the original brake lining assemblies or the original drum brake linings under the same test conditions.
- 2.2.4. The replacement brake lining assembly or the replacement drum brake lining shall be considered to show similar performance characteristics to the original brake lining assembly or the original drum brake lining if the achieved mean fully developed decelerations at the same input force or line pressure in the upper two thirds of the generated curve are within -5 per cent and +15 per cent of those obtained with the original brake lining assembly or the original drum brake lining.

DRAFT GHANA STANDARD

## Annex 7

### Requirements for replacement brake lining assemblies for vehicles of category L

1. Test conditions
  - 1.1. A vehicle which is representative of the type(s) for which the replacement brake lining assembly approval is required shall be equipped with the brake lining assemblies of the type for which approval is requested and instrumented for brake testing as required by Regulation No. 78.
  - 1.2. Brake lining assemblies submitted for the test shall be fitted to the relevant brakes and, until a fixed burnishing procedure is established, shall be burnished to the manufacturer's instructions in agreement with the technical service.
  - 1.3. In the case of brake lining assemblies for vehicles with a combined braking system in the meaning of paragraph 2.9. of Regulation No. 78 the combination(s) of brake lining assemblies for the front and the rear axle to which the approval shall be directed must be tested.

The combination may consist of replacement brake lining assemblies for both axles and/or a replacement brake lining assembly on one and an original brake lining assembly on the other axle.
2. Tests and requirements
  - 2.1. Conformance with Regulation No. 78
    - 2.1.1. The braking system of the vehicle shall be tested according to the requirements for the vehicle category in question ( $L_1$ ,  $L_2$ ,  $L_3$ ,  $L_4$  or  $L_5$ ) in Regulation No. 78, Annex 3, paragraph 1. The applicable requirements or tests are:
      - 2.1.1.1. Type-0 test with engine disconnected

The test is to be carried out only in the laden condition. Make a minimum of six brake applications at spaced increments of control force or line pressure up to wheel lock, or up to a deceleration of  $6 \text{ m/s}^2$  or up to the maximum allowed control force.
      - 2.1.1.2. Type-0 test with engine connected

Only applicable for vehicles of categories  $L_3$ ,  $L_4$  and  $L_5$
      - 2.1.1.3. Type-0 test with wet brakes

Not applicable to vehicles of category  $L_5$  or in cases of drum brakes or fully enclosed disc brakes not subjected to this test during approval to Regulation No. 78.
      - 2.1.1.4. Type-I test

Only applicable for vehicles of categories  $L_3$ ,  $L_4$  and  $L_5$
    - 2.1.2. The vehicle must satisfy all the relevant requirements stated in Regulation No. 78, Annex 3, paragraph 2. for that category of vehicles.

- 2.2. Additional requirements
- 2.2.1. Cold performance equivalence test
- A comparison of the cold performance of the replacement brake lining assembly and the original brake lining assembly shall be made by comparing the results of the Type-0 test as described in paragraph 2.1.1.1.
- 2.2.1.1. The Type-0 test as prescribed in paragraph 2.1.1.1. shall be performed with one set of the original brake lining assembly.
- 2.2.1.2. The replacement brake lining assembly shall be considered to show similar performance characteristics to the original brake lining assembly if the achieved mean fully developed decelerations at the same line pressure in the upper two thirds of the generated curve are within 15 per cent of those obtained with the original brake lining assembly.
- 2.2.2. Speed sensitivity test
- This test is only applicable for vehicles of categories L<sub>3</sub>, L<sub>4</sub> and L<sub>5</sub> and shall be carried out with the laden vehicle under the conditions of the Type-0 test with engine disconnected. However, the test speeds are different.
- 2.2.2.1. From the results of the Type-0 test as described in paragraph 2.1.1.1. determine the control force or line pressure corresponding to the minimum required mean fully developed deceleration for that category of vehicle.
- 2.2.2.2. Using the control force or line pressure determined in paragraph 2.2.2.1. and with initial brake temperature  $\leq 100$  °C, make three brake applications from each of the following speeds:
- 40 km/h, 80 km/h and 120 km/h (if  $v_{\max} \geq 130$  km/h).
- 2.2.2.3. Average the results for each group of three applications and plot speed against corresponding mean fully developed deceleration.
- 2.2.2.4. Mean fully developed decelerations recorded for the higher speeds shall lie within 15 per cent of that recorded for the lowest speed.

## Annex 8

### **Technical prescriptions for replacement brake lining assemblies intended for the use in separate parking brake systems being independent of the vehicle service brake system**

1. Compliance with Regulation No. 13 or 13-H  
Compliance with the requirements of Regulation No. 13 or 13-H shall be demonstrated in a vehicle test.
- 1.1. Vehicle test  
A vehicle which is representative of the type(s) for which the replacement brake lining assembly approval is required shall be equipped with the replacement brake lining assemblies of the type for which approval is requested and instrumented for brake testing as required by Regulation No. 13 or Regulation No. 13-H whichever is appropriate. The vehicle shall be fully laden. Brake linings submitted for test shall be fitted to the relevant brakes and, shall not be burnished.
- 1.2. The parking braking system of the vehicle shall be tested according to all relevant requirements in Regulation No. 13, Annex 4, paragraph 2.3. or Regulation No. 13-H, Annex 3, paragraph 2.3., whichever is appropriate taking into consideration the original approval of the system.

## Annex 9

### Special additional procedures for conformity of production

#### Part A: Determination of friction behaviour by machine testing

1. Introduction

Part A applies to replacement brake lining assemblies or replacement drum brake linings approved to this Regulation.
- 1.1. Samples of a replacement brake lining assembly type shall be tested on a machine capable of generating the test conditions and applying the test procedures described in this annex.
- 1.2. Test results shall be evaluated to determine sample friction behaviour.
- 1.3. The friction behaviour of samples shall be compared to assess conformity with the standard registered for a replacement brake lining assembly type.
2. Replacement brake lining assemblies for vehicles of categories M<sub>1</sub>, M<sub>2</sub>, N<sub>1</sub>, O<sub>1</sub>, O<sub>2</sub>, and L
  - 2.1. Equipment
    - 2.1.1. The machine shall be designed to accept and operate a full size brake similar to those fitted to the vehicle axle used for approval testing to paragraph 5. of this Regulation.
    - 2.1.2. The disc or drum rotational speed shall be  $660 \pm 10$  1/min<sup>1</sup> without load and shall not fall below 600 1/min on full load.
    - 2.1.3. The test cycles and brake applications during the cycles to be adjustable and automatic.
    - 2.1.4. Output torque or brake pressure (constant torque method) and working surface temperature shall be recorded.
    - 2.1.5. Provisions shall be made to direct cooling air across the brake at a rate of  $600 \pm 60$  m<sup>3</sup>/h.
  - 2.2. Test procedure
    - 2.2.1. Sample preparation

The manufacturer's bedding schedule shall ensure a minimum of 80 per cent surface contact area for pad assemblies without exceeding a surface temperature of 300 °C and 70 per cent surface contact area for the leading shoe assemblies without exceeding a surface temperature of 200 °C.

---

<sup>1</sup> In the case of vehicles of categories L<sub>1</sub> and L<sub>2</sub>, a lower test speed may be used.

2.2.2. Test schedule

The test schedule comprises a number of consecutive braking cycles each containing X braking intervals of 5 seconds brake applied followed by 10 seconds brake released.

The following two methods may be used alternatively.

2.2.2.1. Test schedule with constant pressure

2.2.2.1.1. Pad assemblies

The hydraulic pressure p under the piston(s) of the calliper shall be constant following the formula:

$$p = \frac{M_d}{0.57 \cdot r_w \cdot A_k}$$

$M_d = 150 \text{ Nm}$  for  $A_k \leq 18.1 \text{ cm}^2$

$M_d = 300 \text{ Nm}$  for  $A_k > 18.1 \text{ cm}^2$

$A_k$  = area of calliper piston(s)

$r_w$  = effective radius of disc

No of cycle	Number of brake applications X	Initial brake rotor temperature (°C)	Max. brake rotor temperature (°C)	Forced cooling
1	1 x 10	≤ 60	open	no
2-6	5 x 10	100	open (350) <sup>2</sup>	no
7	1 x 10	100	open	yes

2.2.2.1.2. Shoe assemblies

The mean contact pressure at the brake lining working surface shall be constant at  $22 \pm 6 \text{ N/cm}^2$  calculated for a static brake without self-energizing.

No of cycle	Number of brake applications X	Initial brake rotor temperature (°C)	Max. brake rotor temperature (°C)	Forced cooling
1	1 x 10	≤ 60	200	yes
2	1 x 10	100	open	no
3	1 x 10	100	200	yes
4	1 x 10	100	open	no

<sup>2</sup> In the case of vehicles of category L, the temperature shall be limited to 350 °C. If necessary, the number of applications per cycle must be reduced accordingly. However, in this case, the number of cycles shall be increased to keep the total number of applications constant.

2.2.2.2. Test schedule with constant torque

This method applies only for pad assemblies. The brake torque shall be constant within a tolerance of  $\pm 5$  per cent and adjusted to guarantee the maximum brake rotor temperatures given in the table below.

No of cycle	Number of brake applications X	Initial brake rotor temperature (°C)	Max. brake rotor temperature (°C)	Forced cooling
1	1 x 5	$\leq 60$	300-350 (200-250) <sup>3</sup>	no
2-4	3 x 5	100	300-350 (200-250)	no
5	1 x 10	100	500-600 (300-350)	no
6-9	4 x 5	100	300-350 (200-250)	no
10	1 x 10	100	500-600 (300-350)	no
11-13	3 x 5	100	300-350 (200-250)	no
14	1 x 5	$\leq 60$	300-350 (200-250)	no

2.3. Evaluation of test results

Friction behaviour is determined from the brake torque noted at selected points in a test schedule. Where brake factor is constant, e.g. a disc brake, brake torque may be translated to coefficient of friction.

2.3.1. Pad assemblies

2.3.1.1. The operational coefficient of friction ( $\mu_{op}$ ) is the mean of the values recorded during cycles two to seven (constant pressure method) or during cycles 2-4, 6-9 and 11-13 (constant torque method); measurement being made one second after commencing the first brake application of each cycle.

2.3.1.2. The maximum coefficient of friction ( $\mu_{max}$ ) is the highest value recorded during all cycles.

2.3.1.3. The minimum coefficient of friction ( $\mu_{min}$ ) is the lowest value recorded during all cycles.

2.3.2. Shoe assemblies

2.3.2.1. The mean torque ( $M_{mean}$ ) is the average of the maximum and minimum values of brake torque recorded during the fifth brake application of cycles one and three.

2.3.2.2. The hot torque ( $M_{hot}$ ) is the minimum brake torque developed during cycles two and four. If the temperature exceeds 300 °C during these cycles the value at 300 °C is to be taken as  $M_{hot}$ .

2.4. Acceptance criteria

2.4.1. With each application for approval of a brake lining assembly type there shall be submitted:

2.4.1.1. For pad assemblies, values for  $\mu_{op}$ ,  $\mu_{min}$ ,  $\mu_{max}$ .

2.4.1.2. For shoe assemblies, values for  $M_{mean}$  and  $M_{hot}$ .

<sup>3</sup> Values in brackets for vehicles of category L.

- 2.4.2. During production of an approved brake lining assembly type, test samples must demonstrate compliance with the values registered under paragraph 2.4.1. of this annex with the following tolerances:
- 2.4.2.1. For disc brake pads:
- $\mu_{op} \pm 15$  per cent of registered value;
  - $\mu_{min} \geq$  registered value;
  - $\mu_{max} \leq$  registered value.
- 2.4.2.2. For simplex drum brake linings:
- $M_{mean} \pm 20$  per cent of registered value;
  - $M_{hot} \geq$  registered value.
3. Brake lining assemblies and drum brake linings for vehicles of categories M<sub>3</sub>, N<sub>2</sub>, N<sub>3</sub>, O<sub>3</sub>, and O<sub>4</sub>
- 3.1. Equipment
- 3.1.1. The machine shall be equipped with a disc brake of the fixed calliper type with a cylinder diameter of 60 mm and a solid (not ventilated) disc having a diameter of  $278 \pm 2$  mm and a thickness of  $12 \text{ mm} \pm 0.5 \text{ mm}$ . A rectangular piece of the friction material with an area of  $44 \text{ cm}^2 \pm 0.5 \text{ cm}^2$  and a thickness of at least 6 mm shall be attached to the backing plate.
- 3.1.2. The disc rotational speed shall be  $660 \pm 10$  1/min without load and shall not fall below 600 1/min on full load.
- 3.1.3. The mean contact pressure at the brake lining working surface shall be constant at  $75 \text{ N/cm}^2 \pm 10 \text{ N/cm}^2$ .
- 3.1.4. The test cycles and brake applications during the cycles to be adjustable and automatic.
- 3.1.5. Output torque and working surface temperature shall be recorded.
- 3.1.6. Provisions shall be made to direct cooling air across the brake at a rate of  $600 \pm 60 \text{ m}^3/\text{h}$ .
- 3.2. Test procedure
- 3.2.1. Sample preparation
- The manufacturer's bedding procedure shall ensure a minimum of 80 per cent surface contact area without exceeding a surface temperature of 200 °C.



3.2.2. Test schedule

The test procedure comprises a number of consecutive braking cycles each containing a number of X braking intervals of 5 seconds brake applied followed by 10 seconds brake released.

No of cycle	Number of brake applications X	Initial brake rotor temperature (°C)	Forced cooling
1	5	100	yes
2	5	increasing ≤ 200	no
3	5	200	no
4	5	increasing ≤ 300	no
5	5	300	no
6	3	250	yes
7	3	200	yes
8	3	150	yes
9	10	100	yes
10	5	increasing ≤ 300	no
11	5	300	no

3.3. Evaluation of test results

Friction behaviour is determined from the brake torque noted in selected cycles of the test schedule. Brake torque shall be translated to coefficient of friction  $\mu$ .

The  $\mu$ -value of each brake application shall be determined as the mean value of the 5 seconds brake applied.

3.3.1. The operational coefficient of friction  $\mu_{op1}$  is the mean value of  $\mu$  recorded for the brake applications in cycles 1 and  $\mu_{op2}$  is the mean value of  $\mu$  recorded for the brake applications in cycle 9.

3.3.2. The maximum coefficient of friction  $\mu_{max}$  is the highest value of  $\mu$  recorded in an application during cycles 1 to 11 inclusive.

3.3.3. The minimum coefficient of friction  $\mu_{min}$  is the lowest value of  $\mu$  recorded in an application during cycles 1 to 11 inclusive.

3.4. Acceptance criteria

3.4.1. With each application for approval of a replacement brake lining assembly type or a replacement drum brake lining type, there shall be submitted values for  $\mu_{op1}$ ,  $\mu_{op2}$ ,  $\mu_{min}$  and  $\mu_{max}$ .

3.4.2. During production of an approved replacement brake lining assembly type or replacement drum brake lining type, test samples must demonstrate compliance with the values registered under paragraph 3.4.1. of this annex within the following tolerances:

$\mu_{op1}$ ,  $\mu_{op2} \pm 15$  per cent of the registered value;

$\mu_{min} \geq$  registered value;

$\mu_{max} \leq$  registered value.

## **Part B: Conformity of production for brake discs and drums**

1. Introduction  
Part B applies to replacement brake discs and drums approved to this Regulation.
2. Requirements  
Conformity of production is to be demonstrated through the routine control and documentation of at least the following:
  - 2.1. Chemical composition
  - 2.2. Microstructure  
The microstructure must be characterised in accordance with ISO 945-1:2006
    - (a) Description of the composition of the matrix;
    - (b) Description of the graphite shape, distribution and size.
  - 2.3. Mechanical properties
    - (a) Tensile strength measured in accordance with ISO 6892:1998;
    - (b) Brinell hardness measured in accordance with ISO 6506-1:2005.In each case the measurements must be made on samples taken from the actual brake disc or drum.
  - 2.4. Geometric features  
Brake Discs:
    - (a) Thickness variation;
    - (b) Friction surface run out;
    - (c) Friction surface roughness;
    - (d) Cheek thickness variation (for ventilated brake discs).Brake Drums:
    - (a) Ovality;
    - (b) Friction surface roughness.
  - 2.5. Acceptance criteria  
With each application for approval of a replacement brake disc or drum there shall be submitted a production specification covering:
    - (a) Chemical composition and its permitted range, or where appropriate, maximum value, for each element;
    - (b) Microstructure as per paragraph 2.2.;
    - (c) Mechanical properties as per paragraph 2.3. and their permitted range, or where appropriate, minimum value.During routine production of an approved replacement brake disc or drum production must demonstrate compliance with these registered specifications.

In the case of Geometric features the values prescribed in paragraph 5.3.3.1.1. for brake discs and paragraph 5.3.3.1.2. for brake drums must not be exceeded.

2.6. Documentation

The documentation shall contain the manufacturer's maximum and minimum permitted values.

2.7. Test frequency

The measurements prescribed in this annex should be carried out for each production batch.

DRAFT GHANA STANDARD

## Annex 10

### Illustrations

1. Brake disc design types (examples)

#### Flat type

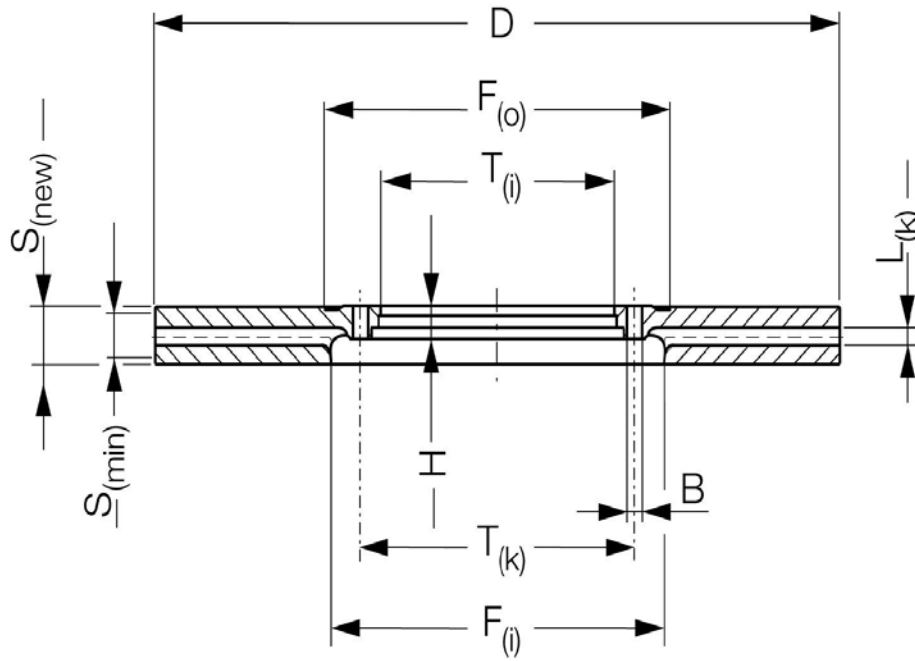

Cylinder type

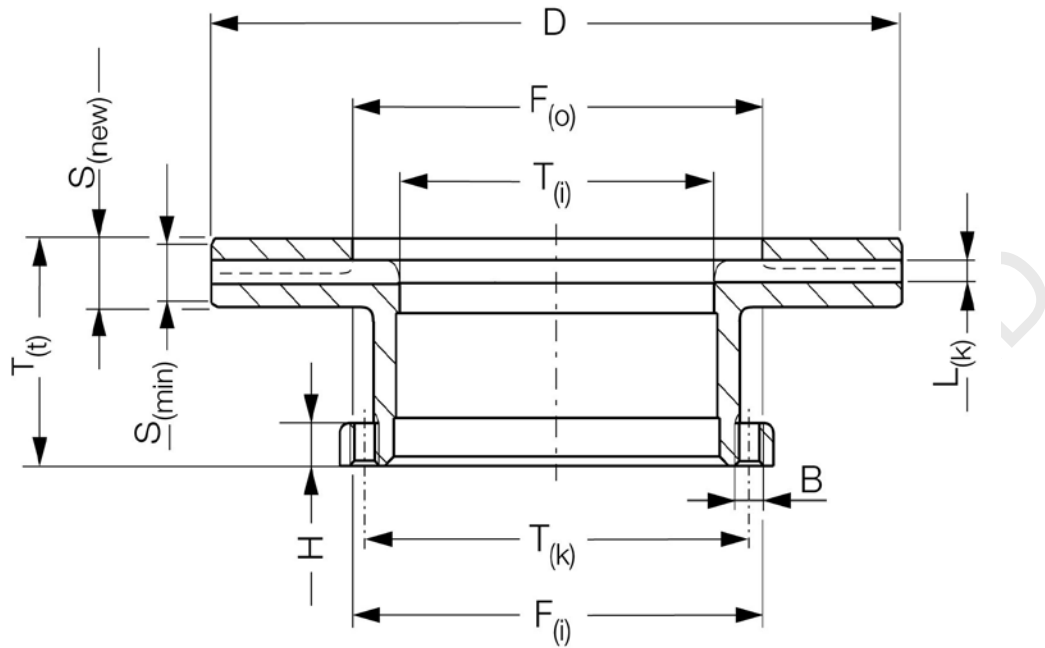

Pot type

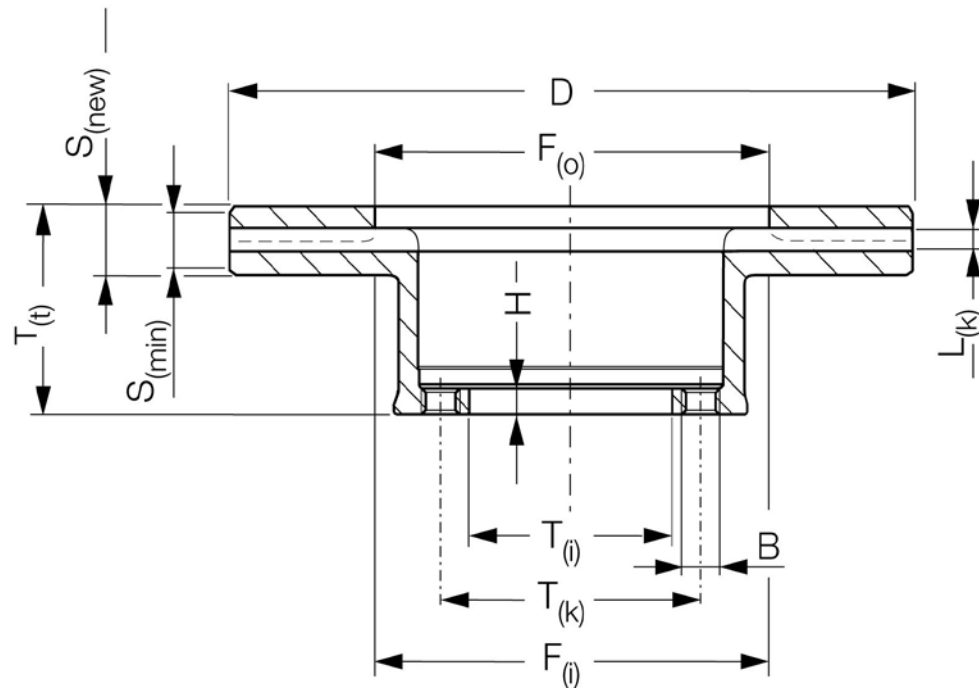

Conical type

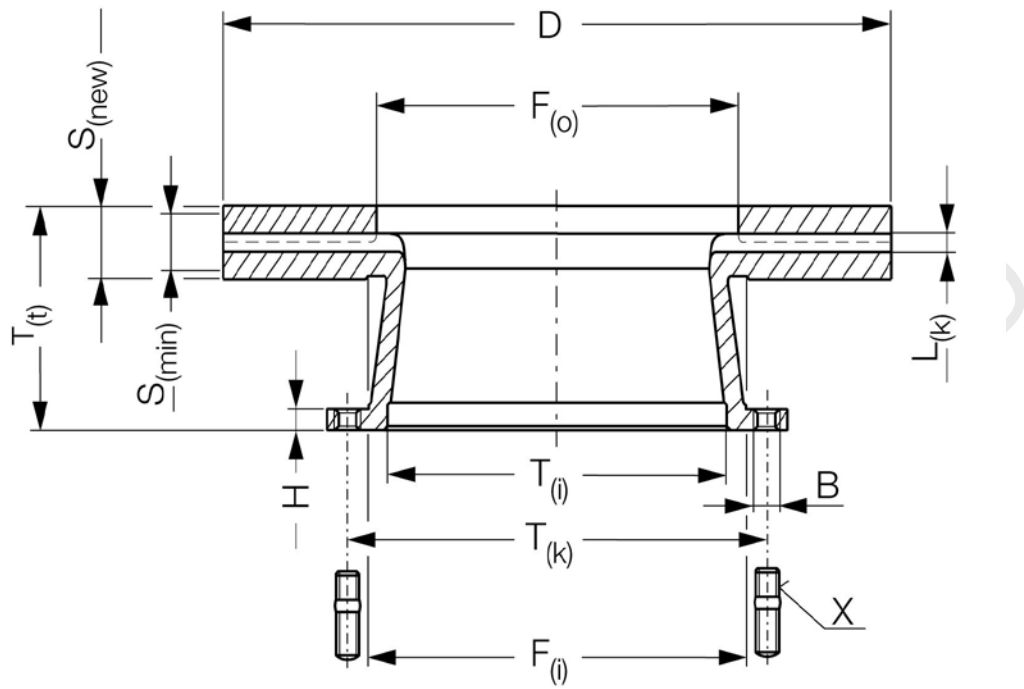

**Double flange type**

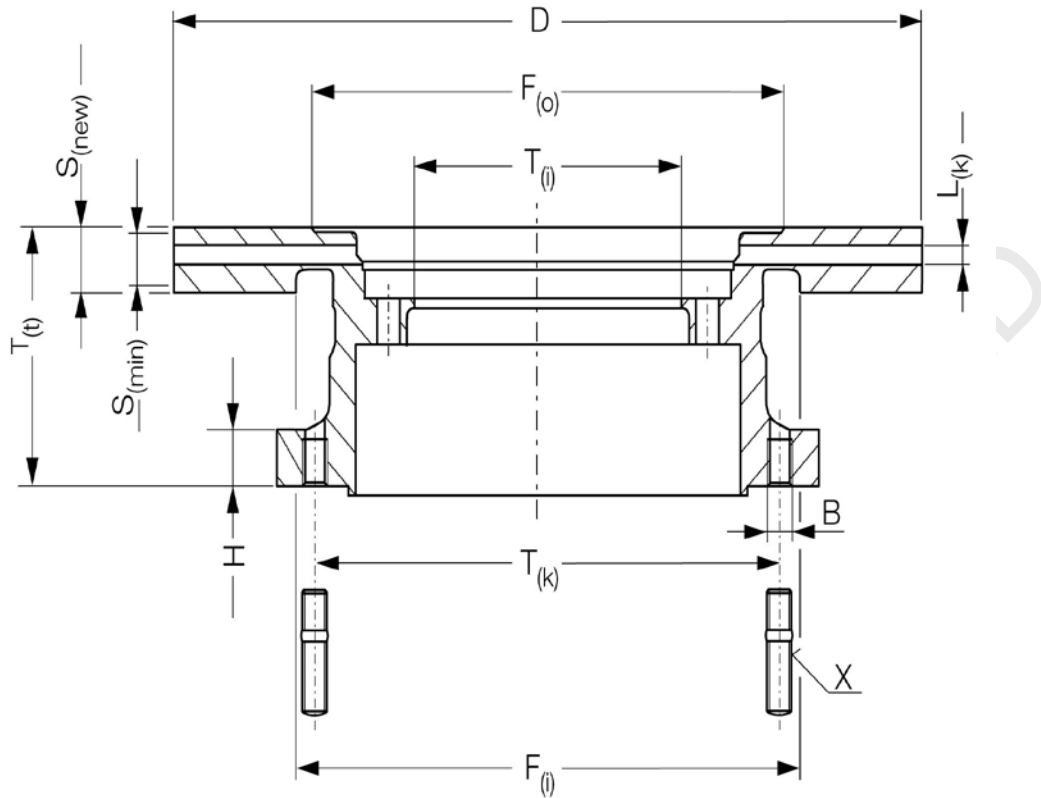

- B Diameter of mounting bolt holes (or thread size in case of threaded holes)
- D External diameter of disc
- $F_{(i)}$  Inner diameter of friction surface (inboard)
- $F_{(o)}$  Inner diameter of friction surface (outboard)
- H Mounting flange thickness
- $L_{(k)}$  Width of cooling (ventilating) channel
- $S_{(new)}$  Disc thickness (nominal)
- $S_{(min)}$  Disc thickness (minimal permissible wear thickness)
- $T_{(i)}$  Internal diameter (mounting spigot diameter)
- $T_{(k)}$  "x" number of mounting bolt holes and pitch circle diameter
- $T_{(t)}$  Overall length of disc

2. Brake drum (example)

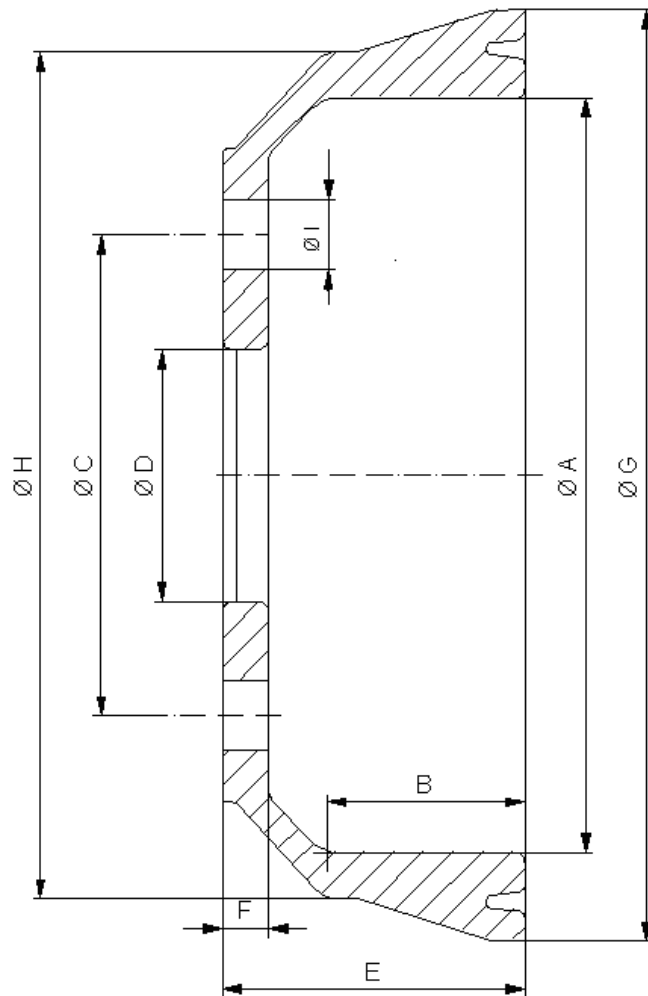

- A Inside diameter of the drum
- B Friction surface width
- C "x" number of mounting bolt holes and pitch circle diameter
- D Mounting spigot diameter
- E Outside drum width
- F Mounting flange thickness
- G Outside diameter of the drum
- H Casing diameter
- I Diameter of the mounting bolt holes



## Annex 11

### Requirements for replacement brake discs or brake drums for vehicles of categories M and N

1. Test overview

The tests required in paragraph 5.3. of this Regulation are detailed as follows according to the vehicle category:

Table A11/1A

**Vehicles of categories M<sub>1</sub>, N<sub>1</sub>**

	<i>Vehicle test</i>	<i>Alternative dynamometer test</i>
Performance tests according to Regulations Nos. 13/13-H	2.2.1. Type 0, engine disconnected	3.4.1. Type 0,
	2.2.2. Type 0, engine connected	3.4.4. Brake tests simulation engine connected Speed and load analog to item 2.2.2.
	2.2.3. Type I	3.4.2. Type I
	2.3. Parking braking system (if applicable)	–
Comparison test with original part	2.4. Testing the dynamic frictional properties (comparison test conducted on the individual axles)	3.5. Testing the dynamic frictional properties (comparison test conducted on the individual wheel brake)
Integrity tests	No vehicle test – use dynamometer test	4.1. Brake discs 4.1.1. Brake disc thermal fatigue test 4.1.2. Brake disc high load test 4.2. Brake drums 4.2.1. Brake drum thermal fatigue test 4.2.2. Brake drum high load test

For each disc and drum type at least one test group (see definition in paragraph 5.3.6. of this Regulation) requires the Type 0 and Type I tests to be carried out on a vehicle.

Table A11/1B  
**Vehicles of categories M<sub>2</sub>, M<sub>3</sub>, N<sub>2</sub>, N<sub>3</sub>**

	<i>Vehicle test</i>	<i>Alternative dynamometer test</i>
Performance tests according to Regulation No. 13	2.2.1. Type 0, engine disconnected	3.4.1. Type 0
	2.2.3. Type I	3.4.2. Type I
	2.2.4. Type II	3.4.3. Type II
	2.3. Parking braking system (if required)	–
Comparison test with original part	2.4. Testing the dynamic frictional properties (comparison test conducted on the individual axles)	3.5. Testing the dynamic frictional properties (comparison test conducted on the individual wheel brake)
Integrity tests	No vehicle test – use dynamometer test	4.1. Brake discs 4.1.1. Thermal fatigue 4.1.2. High load test 4.2. Brake drums 4.2.1. Thermal fatigue 4.2.2. High load test

2. Verification of the vehicle test requirements

2.1. Test vehicle

A vehicle that is representative for the selected test group (see definition in paragraph 5.3.6. of this Regulation) in respect of which an approval or parts report for a replacement brake disc/drum is applied for shall be fitted with this replacement brake disc/drum as well as be equipped with test devices for testing the brakes pursuant to the provisions of Regulation No. 13 or 13-H.

The replacement brake disc/drum shall be fitted to the axle in question together with an accompanying brake lining which has been type approved according to Regulations Nos. 13 or 13-H or 90 available from the vehicle or axle manufacturer.

Unless a uniform procedure is laid down for how braking is to be effected, the test shall be carried out following agreement with the Technical Service. All the tests listed below shall be carried out on brakes that have been bedded in.

The same "bedding-in" programme shall be used for both replacement and original brake discs and drums.

2.2. Service braking system

2.2.1. Type 0 brake tests, engine disconnected, vehicle laden

This test shall be carried out pursuant to Regulation No. 13, Annex 4, paragraph 1.4.2. or Regulation No. 13-H, Annex 3, paragraph 1.4.2.

- 2.2.2. Type 0 brake tests, engine connected, vehicle unladen and laden  
This test shall be carried out pursuant to Regulation No. 13, Annex 4, paragraph 1.4.3. (supplementary test, how the vehicle behaves when braking from high speed) or Regulation No. 13-H, Annex 3, paragraph 1.4.3.
- 2.2.3. Type I brake tests  
This test shall be carried out pursuant to Regulation No. 13, Annex 4, paragraph 1.5.1. or Regulation No. 13-H, Annex 3, paragraph 1.5.1.  
At the end of the Type I brake test, the performance when the brakes are hot is to be satisfied pursuant to Regulation No. 13, Annex 4, paragraph 1.5.3. or Regulation No. 13-H, Annex 3, paragraph 1.5.2.
- 2.2.4. Type II brake tests  
This test shall be carried out pursuant to Regulation No. 13, Annex 4, paragraph 1.6.
- 2.3. Parking braking system (if required)
- 2.3.1. If the service brake system and the parking brake system use a common disc or drum friction surface, it is not necessary to conduct a specific parking brake system test. The satisfactory achievement of the Type 0 laden test shall be taken as meeting the parking brake system requirements.
- 2.3.2. Static test with 18 per cent gradient, vehicle laden
- 2.3.3. The vehicle shall satisfy all the relevant provisions laid down in Regulation No. 13, Annex 4, paragraph 2.3. or Regulation No. 13-H, Annex 3, paragraph 2.3. that apply to this category of vehicle.
- 2.4. Testing the dynamic frictional properties (comparison test conducted on the individual axles)  
For this test, the vehicle shall be laden and all brake applications carried out on a flat road with the engine disconnected.  
The service braking system of the vehicle shall be provided with a device that separates the front-wheel brakes from the rear-wheel brakes so that they can always be operated independently of one another.  
If an approval or a part report is required in connection with a replacement brake disc/drum for the front-wheel brakes, the rear-wheel brakes shall remain inoperative throughout the test.  
If an approval or a part report is required in connection with a replacement brake disc/drum for the rear-wheel brakes, the front-wheel brakes shall remain inoperative throughout the test.
- 2.4.1. Performance comparison test when the brakes are cold  
With cold brakes, the performance of the replacement brake disc/drum shall be compared with the original equivalents by comparing the results of the test below.
- 2.4.1.1. Using the replacement brake disc/drum, at least six consecutive brake applications with different, gradually increasing control forces or brake pressures are carried out as part of the process up to the point at which the wheels lock, or up to a mean fully developed deceleration of  $6 \text{ m/s}^2$  ( $M_1, M_2, N_1$ ) or  $3.5 \text{ m/s}^2$  ( $M_3, N_2, N_3$ ) or up to the maximum control force or line

pressure permitted for this category of vehicle, in which connection the initial speed for the testing of front or rear axle brake discs and drums is as per the table below:

Table A11/2.4.1.1.

Vehicle category	Test speed in km/h	
	Front axle	Rear axle
M <sub>1</sub>	70	45
M <sub>2</sub>	50	40
N <sub>1</sub>	65	50
M <sub>3</sub> , N <sub>2</sub> , N <sub>3</sub>	45	45

Prior to each brake application, the initial temperature of the brake disc/drum shall be  $\leq 100$  °C.

2.4.1.2. The brake test described in paragraph 2.4.1.1. also has to be carried out using the original brake disc/drum.

2.4.1.3. The dynamic frictional properties of the replacement brake disc/drum can be regarded as similar to those of the original brake disc/drum, provided the values attained in relation to the mean fully developed deceleration at the same operating pressures or control forces in the region of the upper 2/3 of the curve generated do not deviate by either  $\pm 10$  per cent or  $\pm 0.4$  m/s<sup>2</sup> from those of the original brake disc/drum.

3. Inertia dynamometer test

3.1. Equipping the dynamometer

For testing purposes, the dynamometer shall be fitted out with the original brake caliper or wheel brake of the vehicle(s) concerned. The inertia dynamometer shall be equipped with a constant torque device and equipment for recording rotational speed, brake pressure, the number of revolutions after braking has commenced, brake torque, the braking period and the temperature of the brake discs/drums on a continuous basis.

3.2. Test conditions

3.2.1. Inertia mass of the inertia dynamometer

The inertia mass of the inertia dynamometer shall be set as close as possible, with a permissible variation of  $\pm 5$  per cent, to the theoretically required value which corresponds to that part of the total inertia of the vehicle braked by the appropriate wheel. The formula used for calculation purposes is as follows:

$$I = m \cdot r_{\text{dyn}}^2$$

Where:

I = rotary inertia (kgm<sup>2</sup>);

r<sub>dyn</sub> = dynamic rolling radius of the tyre (m);

m = test mass (part of the maximum mass of the vehicle braked by the appropriate wheel) as stipulated by this Regulation.

3.2.1.1. Dynamic rolling radius

In calculating the inertia mass, the dynamic rolling radius ( $r_{dyn}$ ) of the largest tyre authorised for the vehicle (or the axle) shall be taken into account.

3.2.1.2. Test mass

The test mass for calculating the inertia mass shall be as follows:

- a) When testing front axle brake discs and drums:

$$m = \frac{x \cdot m_{veh}}{2 \cdot n_{front}} \quad \begin{array}{l} m_{veh} = \text{max. permitted mass of the vehicle} \\ n_{front} = \text{number of front axles} \end{array}$$

- b) When testing rear axle brake discs and drums:

$$m = \frac{y \cdot m_{veh}}{2 \cdot n_{rear}} \quad \begin{array}{l} m_{veh} = \text{max. permitted mass of the vehicle} \\ n_{rear} = \text{number of rear axles} \end{array}$$

Table A11/3.2.1.2

Vehicle category	Percentage by mass <i>m</i> to be taken into account	
	<i>X</i> values (front axle)	<i>Y</i> values (rear axle)
M1	77	32
M <sub>2</sub>	69	44
N <sub>1</sub>	66	39
M <sub>3</sub> , N <sub>2</sub> , N <sub>3</sub>	55	55

3.2.2. The initial rotational speed of the dynamometer shall correspond to the linear speed of the vehicle at 80 km/h (M<sub>1</sub>, N<sub>1</sub>) or 60 km/h (M<sub>2</sub>, M<sub>3</sub>, N<sub>2</sub>, N<sub>3</sub>) based on the mean of the dynamic rolling radii of the largest and smallest tyre of the authorised tyre sizes.

3.2.3. Cooling

The cooling may be carried out either to paragraphs 3.2.3.1. or 3.2.3.2.

3.2.3.1. Test carried out with a complete wheel (rim and tyre), mounted on the moving part of the brake, as it would be on the vehicle (worst case).

With respect to the Type I and Type II tests air cooling at a velocity and air flow direction simulating actual conditions may be used during the heating runs, the speed of the air flow being  $v_{Air} = 0.33 v$

Where:

$v$  = vehicle test speed at initiation of braking.

In other cases cooling air is not restricted.

The temperature of the cooling air shall be the ambient temperature.

3.2.3.2. Test carried out without a rim

With respect to the Type I and Type II tests during the heating runs no cooling is allowed.

In other cases cooling air is not restricted.

3.2.4. Preparation of the brake

3.2.4.1. Disc brakes

The test is conducted using a new disc with new brake lining assemblies which have been type approved according to Regulation No. 13, 13-H or 90 (in the condition as mounted on the vehicle, e.g. protective grease removed).

3.2.4.2. Drum brakes

The test is conducted using a new drum with new linings assemblies which have been type approved according to Regulation No. 13, 13-H or 90 (if applicable, protective grease removed).

Machining of the linings to achieve good lining to drum contact is permissible.

3.3. Alternative dynamometer performance test

Table A11/3.3.

	<i>In the case of vehicles of categories M<sub>1</sub>, M<sub>2</sub>, N<sub>1</sub></i>
1a.	<i>See bedding-in (burnishing) procedure as described in Annex 3, paragraph 2.2.2.3.</i>
1b.	In the case of vehicles of categories M <sub>3</sub> , N <sub>2</sub> , N <sub>3</sub> Bedding-in (burnishing): 100 (disc) or 200 (drum) brake applications T <sub>i</sub> = 150 °C (disc) or 100 °C (drum) v <sub>i</sub> = 60 km/h d <sub>m</sub> = 1 and 2 m/s <sup>2</sup> alternating
2.	Dynamic friction properties, see paragraph 3.5.1. of this annex
3.	Brake test Type 0, see paragraph 3.4.1. of this annex
4.	Brake test Type I, see paragraph 3.4.2. of this annex
5.	Re-burnishing: 10 (disc) or 20 (drum) brake applications T <sub>i</sub> = 150 °C (disc) or 100 °C (drum) v <sub>i</sub> = 60 km/h, d <sub>m</sub> = 1 and 2 m/s <sup>2</sup> alternating
6.	Brake test Type 0, see paragraph 3.4.1. of this annex
7.	Brake tests simulation engine connected, see paragraph 3.4.4. of this annex
8.	Re-burnishing: (like No. 5.)
9.	Dynamic friction properties, see paragraph 3.5.1 of this annex
10.	Brake test Type II (if applicable), see paragraph 3.4.3. of this annex
11.	Re-burnishing: (like No. 5.)
	Steps 12 to 19 are optional (if activation is not sufficient)
12.	Brake test Type 0, see paragraph 3.4.1. of this annex

	<i>In the case of vehicles of categories M<sub>1</sub>, M<sub>2</sub>, N<sub>1</sub></i>
1a.	<i>See bedding-in (burnishing) procedure as described in Annex 3, paragraph 2.2.2.3.</i>
13.	Brake test Type I, see paragraph 3.4.2. of this annex
14.	Re-burnishing: (like item 5.)
15.	Dynamic friction properties, see paragraph 3.5.1. of this annex
16.	Brake tests simulation engine connected, see paragraph 3.4.4. of this annex
17.	Re-burnishing: (like item 5.)
18.	Dynamic friction properties, see paragraph 3.5.1. of this annex
19.	Re-burnishing: (like item 5.)

3.4. Service braking system

3.4.1. Brake tests Type 0, vehicle laden

This test shall be carried out analogous to the provisions of Regulation No. 13, Annex 4, paragraph 1.4.2. or Regulation No. 13-H, Annex 3, paragraph 1.4.2.

3.4.2. Brake tests Type I

This test shall be carried out analogous to the provisions of Regulation No. 13, Annex 4, paragraph 1.5.1. or Regulation No. 13-H, Annex 3, paragraph 1.5.1.

At the end of the Type I brake test, the performance when the brakes are hot is to be satisfied pursuant to Regulation No. 13, Annex 4, paragraph 1.5.3. or Regulation No. 13-H, Annex 3, paragraph 1.5.2.

3.4.3. Brake tests Type II

This test shall be carried out analogous to the provisions of Regulation No. 13, Annex 4, paragraph 1.6.

3.4.4. Brake tests simulation engine connected

Instead of the Type 0 test with engine connected, for the purpose of this Regulation it is acceptable to carry out a test to simulating for the laden condition (see paragraph 3.2. of this annex) the test conditions which are prescribed for the Type 0 test with engine connected in Regulation No. 13, Annex 4, paragraph 2.1.1. or Regulation No. 13-H, Annex 3, paragraph 2.1.1.

3.5. Testing the dynamic frictional properties (comparison test conducted on the individual wheel brake)

With cold brakes, the performance of the replacement brake disc/drum shall be compared with the original equivalents by comparing the results of the test below.

3.5.1. Using the replacement brake disc/drum, at least six consecutive brake applications with different, gradually increasing control forces or brake pressures are carried out as part of the process up to a mean fully developed deceleration of 6 m/s<sup>2</sup> (M<sub>1</sub>, M<sub>2</sub>, N<sub>1</sub>) or 5 m/s<sup>2</sup> (M<sub>3</sub>, N<sub>2</sub>, N<sub>3</sub>). The control forces or line pressure have not to exceed the maximum allowed control forces or line pressure that is permanently guaranteed by the braking system of the vehicle (e. g. cut in pressure of the compressor). Prior to each brake application, the initial temperature of the brake disc/drum shall be ≤ 100 °C.

3.5.2. The brake test described in paragraph 3.5.1. also has to be carried out using the original brake disc/drum.

3.5.3. The dynamic frictional properties at the end of the procedure (step 9 or 18) of the replacement brake disc/drum can be regarded as similar to those of the original brake disc/drum, provided the values attained in relation to the mean fully developed deceleration at the same operating pressures or control forces in the region of the upper 2/3 of the curve generated do not deviate by either ±8 per cent or ±0.4 m/s<sup>2</sup> from those of the original brake disc/drum.

#### 4. Integrity tests using an inertia dynamometer

The tests are conducted in accordance with paragraph 4.1. (discs) or 4.2. (drums).

A single test per test group is required unless the replacement part does not achieve the required number of cycles before damage or failure (see paragraph 4.1.1.1.3. or 4.1.1.2.3. of this annex).

The brake should be installed on the dynamometer in accordance with its fitting position on the vehicle (rigidly mounted brakes or those installed by means of a stub axle are exempt).

The temperature of the brake disc/brake drum should be measured in as close proximity to the friction rubbing surface as possible. The temperature measurement should be recorded and the method and measuring point shall be the same for all tests.

If cooling air is used during a brake application or between brake applications inside one braking cycle, the speed of the airflow at the brake shall be limited to  $v_{\text{air}} = 0.33 v$

Where:

$v$  = vehicle test speed at initiation of braking.

In other cases cooling air is not restricted.

The temperature of the cooling air shall be the ambient temperature.

#### 4.1. Brake discs

##### 4.1.1. Brake disc thermal fatigue test

This test is conducted using a new disc, an original brake caliper of the vehicle(s) concerned and new brake lining assemblies of the vehicle(s) concerned which have been type approved according to Regulation No. 13, 13-H or 90 (in the condition as mounted on the vehicle, e.g. protective grease removed).

Worn brake linings may be replaced during the test if necessary.



- 4.1.1.1. Vehicles of categories  $M_1, N_1$
- 4.1.1.1.1. Test conditions (brake disc thermal fatigue test)
- The inertia mass of the inertia dynamometer shall be determined in accordance with the requirements laid down in paragraphs 3.2.1., 3.2.1.1. and 3.2.1.2. of Annex 11.
- The rotational speed of the dynamometer shall correspond to the linear test speed of the vehicle based on the mean of the largest and smallest dynamic rolling radius of the tyres authorized for that vehicle.
- 4.1.1.1.2. Test program (brake disc thermal fatigue test)
- Brake linings submitted for test shall be fitted to the relevant brakes and bedded (burnished) according to the procedure of Annex 3, paragraph 1.1.2.:

Table A11/4.1.1.1.2.

Test provision	Thermal fatigue test
Vehicle categories	$M_1, N_1$
Type of braking	Sequential brake applications
Braking interval (= $t_{total}$ )	70 s
Number of brake applications per cycle	2
Brake torque in accordance with a deceleration of	$5.0 \text{ m/s}^2$
Total number of braking cycles	100 or 150 (see 4.1.1.1.3.)
Brake applications from to	$v_{max}$ 20 km/h
Initial temperature of the 1st brake application in each cycle	$\leq 100 \text{ }^\circ\text{C}$

Where:

- $v_{max}$  the  $v_{max}$  to be used to test the replacement part is that corresponding to the vehicle which has the highest ratio of kinetic energy to disc mass;
- $t_{bra}$  actual braking period during the application;
- $t_{acc}$  minimum acceleration time in accordance with the accelerating power of the respective vehicle;
- $t_{rest}$  rest period;
- $t_{total}$  Braking interval ( $t_{bra} + t_{acc} + t_{rest}$ ).

- 4.1.1.1.3. Test result (brake disc thermal fatigue test)
- The test is regarded as having been passed if 150 or more cycles are completed without damage or failure.
- If less than 150 cycles but more than 100 cycles are completed without damage or failure then the test must be repeated on a new replacement part.

Under these circumstances both tests must complete more than 100 cycles without damage or failure for the part to have passed the test.

If less than 100 cycles are completed before damage or failure then a test should be conducted on the original part and the results compared. If the damage or failure point is no worse than the number of cycles of the original part -10 per cent then the test is regarded as having been passed.

Damage in this context means:

- (a) Radial cracks on the friction surface which are longer than 2/3 of the radial height of the friction surface;
- (b) Cracks on the friction surface which reach the inner or outer diameter of the friction surface;
- (c) Through-cracking of any friction ring;
- (d) Any type of structural damage or cracks in any area outside the friction surface.

4.1.1.2. Vehicles of categories M<sub>2</sub>, M<sub>3</sub>, N<sub>2</sub> and N<sub>3</sub>

4.1.1.2.1. Test conditions (brake disc thermal fatigue test)

4.1.1.2.1.1. Vehicles with a maximum permissible mass > 7.5 t

By means of the following Test program, brake discs are tested as components of the braking system. It does not imitate actual driving conditions but is understood as being purely a component test. The parameters listed below in Table A11/4.1.1.2.1.1. cover the brakes that are presently used as a rule on vehicles with a maximum permitted mass > 7.5 t.

Table A11/4.1.1.2.1.1.

<i>Outside disc diameter</i>	<i>Test parameter</i>	<i>Test parameter</i>	<i>Example of equipment</i>
	<i>Test mass m [kg]</i>	<i>r<sub>dyn</sub> [m]</i>	<i>"Brake size"/smallest possible rim size</i>
320-350	3,100	0.386	17.5"
351-390	4,500	0.445	19.5"
391-440	5,300	0.527	22.5"
> 440*	*	*	—

\* The test mass and the dynamic tyre rolling radius to be agreed between the applicant and the Technical Service.

The inertia mass of the inertia dynamometer shall be determined in accordance with the requirements laid down in paragraph 3.2.1. of Annex 11 in conjunction with the parameters specified in the table above (test mass and r<sub>dyn</sub>).

The rotational speed of the dynamometer shall correspond to the linear test speed of the vehicle based on the dynamic tyre rolling radii specified in Table A11/4.1.1.2.1.1.

4.1.1.2.1.2. Vehicles with a maximum permissible mass > 3.5 t and ≤ 7.5 t

As regards vehicles with a maximum permitted mass > 3.5 t and ≤ 7.5 t in respect of which the parameters listed in Table A11/4.1.1.2.1.1. do not apply, the test parameters shall be selected in such a way that the worst case scenario that formed the basis of the range of use of the replacement brake disc (maximum permitted vehicle mass, maximum tyre equipment size) is covered.

The inertia mass of the inertia dynamometer shall be determined in accordance with the requirements laid down in paragraphs 3.2.1., 3.2.1.1. and 3.2.1.2. of Annex 11.

The rotational speed of the dynamometer shall correspond to the linear test speed of the vehicle based on the mean of the largest and smallest dynamic rolling radius of the tyres authorized for that vehicle.

4.1.1.2.2. Test program (brake disc thermal fatigue test)

Table A11/4.1.1.2.2.

"Bedding-in" procedure	100 brake applications Initial speed: 60 km/h Final speed: 30 km/h $d_m$ alternating between 1 m/s <sup>2</sup> and 2 m/s <sup>2</sup> Initial temperature : ≤ 300 °C (beginning at room temperature)
1. Conditioned braking	10 brake applications from 60 to 30 km/h $d_m$ alternating between 1 m/s <sup>2</sup> and 2 m/s <sup>2</sup> Initial temperature: ≤ 250 °C
2. High-speed braking	2 Brake applications from 130 to 80 km/h $d_m$ 3 m/s <sup>2</sup> Initial temperature: ≤ 100 °C
3. Conditioned braking	See test stage 1
4. High-speed braking	See test stage 2
5. Conditioned braking	See test stage 1
6. Continuous braking (1)	5 Brake applications at a constant speed of: 85 km/h Decelerating torque corresponding to 0.5 m/s <sup>2</sup> Braking period 60 s Initial temperature: ≤ 80 °C
7. Conditioned braking	See test stage 1
8. Continuous braking (2)	5 Brake applications at a constant speed of: 85 km/h Decelerating torque corresponding to 1.0 m/s <sup>2</sup> Braking period 40 s Initial temperature: ≤ 80 °C
9. Repeat test stages 1 to 8:	9 or 14 times (whichever is applicable) – see paragraph 4.1.1.2.3.

$d_m$  distance related mean deceleration.

4.1.1.2.3. Test result (brake disc thermal fatigue test)

The test is regarded as having been passed if 15 or more cycles are completed without damage or failure.

If less than 15 cycles but more than 10 cycles are completed without damage or failure then the test must be repeated on a new replacement part. Under these circumstances both tests must complete more than 10 cycles without damage or failure for the part to have passed the test.

If less than 10 cycles are completed before damage or failure then a test should be conducted on the original part and the results compared. If the damage or failure point is no worse than the number of cycles of the original part then the test is regarded as having been passed.

Damage in this context means:

- (a) Radial cracks on the friction surface which are longer than 2/3 of the radial height of the friction ring;
- (b) Cracks on the friction surface which reach the inner or outer diameter of the friction surface;
- (c) Through-cracking of any friction ring;
- (d) Any type of structural damage or cracks in any area outside the friction surface.

4.1.2. Brake disc high load test

This test is conducted using a new disc, an original brake caliper of the vehicle(s) concerned and new brake lining assemblies of the vehicle(s) concerned which have been type approved according to Regulations Nos. 13, 13-H or 90 (in the condition as mounted on the vehicle, e.g. protective grease removed).

Worn brake linings may be replaced during the test if necessary.

4.1.2.1. Vehicles of categories  $M_1$ ,  $N_1$

4.1.2.1.1. Test conditions (brake disc high load test)

See paragraph 4.1.1.1.1. above.

4.1.2.1.2. Test program (brake disc high load test)

The test has to be carried out according to the following table:

Table A11/4.1.2.1.2.

Test provision	High load test
Vehicle categories	$M_1$ , $N_1$
Type of braking	Single brake applications
Number of brake applications	70
Initial temperature at the beginning of braking	$\leq 100$ °C
Brake torque in accordance with	10.0 m/s <sup>2</sup> (however, brake pressure $p \leq 16,000$ kPa)
Brake applications from to	$v_{max}$ 10 km/h

Where:

$v_{\max}$  the  $v_{\max}$  to be used to test the replacement part is that corresponding to the vehicle which has the highest ratio of kinetic energy to disc mass.

4.1.2.1.3. Test result (brake disc high load test)

The test is regarded as having been passed if 70 or more brake applications are completed without damage or failure.

If less than 70 brake applications are completed before damage or failure then a test should be conducted on the original part and the results compared. If the damage or failure point is no worse than the number of cycles of the original part -10 per cent then the test is regarded as having been passed.

Damage in this context means:

- (a) Radial cracks on the friction surface which are longer than 2/3 of the radial height of the friction surface;
- (b) Cracks on the friction surface which reach the inner or outer diameter of the friction surface;
- (c) Through-cracking of any friction ring;
- (d) Any type of structural damage or cracks in any area outside the friction surface.

4.1.2.2. Vehicles of categories M<sub>2</sub>, M<sub>3</sub>, N<sub>2</sub> and N<sub>3</sub>

4.1.2.2.1. Test conditions (brake disc high load test)

See paragraph 4.1.1.2.1. above.

4.1.2.2.2. Test program (brake disc high load test)

500 brake applications are carried out from a speed of 50 km/h to 10 km/h with a brake torque of 90 per cent of the maximum brake torque specified by the applicant.

Initial temperature:  $\leq 200$  °C

4.1.2.2.3. Test result (brake disc high load test)

The test is regarded as having been passed if the brake disc does not exhibit any signs of fracture after 500 brake applications.

4.2. Brake drums

4.2.1. Brake drum thermal fatigue test

The test is conducted using a new drum with new linings assemblies which have been type approved according to Regulations No. 13, 13-H or 90 (if applicable, protective grease removed).

Machining of the linings to achieve good lining to drum contact is permissible.

4.2.1.1. Vehicles of categories M<sub>1</sub> and N<sub>1</sub>

4.2.1.1.1. Test conditions (brake drum thermal fatigue test)

The inertia mass of the inertia dynamometer shall be determined in accordance with the requirements laid down in paragraphs 3.2.1., 3.2.1.1. and 3.2.1.2. of Annex 11.

The rotational speed of the dynamometer shall correspond to the linear test speed of the vehicle based on the mean of the largest and smallest dynamic rolling radius of the tyres authorized for that vehicle.

4.2.1.1.2. Test program (brake drum thermal fatigue test)

The thermal fatigue requirements for brake drums are covered by the high load tests of paragraph 4.2.2.1.2.

4.2.1.1.3. Test result (brake drum thermal fatigue)

See paragraph 4.2.2.1.3.

4.2.1.2. Vehicles of categories M<sub>2</sub>, M<sub>3</sub>, N<sub>2</sub>, N<sub>3</sub>

4.2.1.2.1. Test conditions (brake drum thermal fatigue test)

4.2.1.2.1.1. Vehicles with a maximum permissible mass > 7.5 t

By means of the following Test program, brake discs are tested as components of the braking system. It does not imitate actual driving conditions but is understood as being purely a component test. The parameters listed below in Table A11/4.2.1.2.1.1. cover the brakes that are presently used as a rule on vehicles with a maximum permitted mass > 7.5 t.

Table A11/4.2.1.2.1.1.

Inner drum diameter [mm]	Lining width						Typical rim diameter
	< 130 mm		130-190 mm		>190 mm		
	Test mass [kg]	Tyre radius [m]	Test mass [kg]	Tyre radius [m]	Test mass [kg]	Tyre radius [m]	
< 330	2750	0.402	3200	0.390	5500	0.402	17.5"
330-390	*	*	3400	0.480	5500	0.516	19.5"
391-430	3400	0.510	4500	0.527	5500	0.543	22.5"
> 430	*	*	*	*	*	*	—

\* The test mass and the dynamic tyre rolling radius to be agreed between the applicant and the Technical Service.

The inertia mass of the inertia dynamometer shall be determined in accordance with the requirements laid down in paragraph 3.2.1. of Annex 11 in conjunction with the parameters specified in the table above (test mass and  $r_{dyn}$ ).

The rotational speed of the dynamometer shall correspond to the linear test speed of the vehicle based on the dynamic tyre rolling radii specified in Table A11/4.2.1.2.1.1.

4.2.1.2.1.2. Vehicles with a maximum permissible mass > 3.5 t and ≤ 7.5 t

As regards vehicles with a maximum permitted mass > 3.5 t and ≤ 7.5 t in respect of which the parameters listed in Table A11/4.1.1.2.1.1. do not apply, the test parameters shall be selected in such a way that the worst case scenario that formed the basis of the range of use of the replacement brake disc (maximum permitted vehicle mass, maximum tyre equipment size) is covered.

The inertia mass of the inertia dynamometer shall be determined in accordance with the requirements laid down in paragraphs 3.2.1., 3.2.1.1. and 3.2.1.2. of Annex 11.

The rotational speed of the dynamometer shall correspond to the linear test speed of the vehicle based on the mean of the largest and smallest dynamic rolling radius of the tyres authorized for that vehicle.

4.2.1.2.2. Test program (brake drum thermal fatigue test)

Table A11/4.2.1.2.2.

Test provision	Thermal fatigue test
Type of braking	Sequential brake applications
Number of brake applications	250 or 300 (whichever is applicable) – see paragraph 4.2.1.2.3. <i>NB:</i> The test is interrupted when a through crack appears.
Brake torque in accordance with	3.0 m/s <sup>2</sup>
Brake applications from to	130 80 km/h
Initial temperature of each brake application	≤ 50 °C
Cooling pursuant to paragraph 3.2.3.	permitted

4.2.1.2.3. Test result (brake drum thermal fatigue)

The test is regarded as having been passed if 300 or more brake applications are completed without damage or failure.

If less than 300 brake applications but more than 250 brake applications are completed without damage or failure then the Technical Service must repeat the test on a new replacement part. Under these circumstances both tests must complete more than 250 brake applications without damage or failure for the part to have passed the test.

If less than 250 brake applications are completed before damage or failure then a test should be conducted on the original part and the results compared – if the damage or failure point is no worse than the original part then the test is regarded as having been passed.

Damage in this context means:

- (a) Cracks on the friction surface which are longer than 2/3 of the axial width of the friction surface;
- (b) Cracks on the friction surface which reach the axial outer end of the drum;
- (c) Through-cracking of the drum;
- (d) Any type of structural damage or cracks in any area outside the friction surface.

4.2.2. Brake drum high load test

The high load test shall be conducted on the same test specimens following the alternative dynamometer test (see paragraph 3.3. of this annex.).

4.2.2.1. Vehicles of categories M<sub>1</sub> and N<sub>1</sub>

4.2.2.1.1. Test conditions (brake drum high load test)

See paragraph 4.2.1.1.1. above.

4.2.2.1.2. Test program (brake drum high load test)

Table A11/4.2.2.1.2.

"Bedding-in" procedure	Make 100 consecutive snub applications with $v_1 = 80$ km/h and $v_2 = 10$ km/h and an initial temperature of $\leq 100$ °C.  The deceleration of the first application shall be constant $1.5$ m/s <sup>2</sup> . From the second up to the last application the pressure shall be constant and equivalent to the average of the first application.  The bedding should be continued until a minimum of 80 per cent lining to drum contact is achieved.
Test provision	Brake drum high load test
Type of braking	Single brake applications
Number of brake applications	100
Initial temperature at the beginning of braking	$\leq 100$ °C
Brake torque in accordance with	$10.0$ m/s <sup>2</sup> (however, brake pressure $p \leq 16,000$ kPa)
Brake applications from to	$v_{max}$ 10 km/h

$v_{max}$  the  $v_{max}$  to be used to test the replacement part is that corresponding to the vehicle which has the highest ratio of kinetic energy to disc mass.

4.2.2.1.3. Test result (brake drum high load test)

The test is regarded as having been passed if 100 or more brake applications are completed without damage or failure.

If less than 100 brake applications are completed before damage or failure then a test should be conducted on the original part and the results compared. If the damage or failure point is no worse than the number of cycles of the original part -10 per cent then the test is regarded as having been passed.

Damage in this context means:

- (a) Cracks on the friction surface which are longer than 2/3 of the axial width of the friction surface;



- (b) Cracks on the friction surface which reach the axial outer end of the drum;
- (c) Through-cracking of the drum;
- (d) Any type of structural damage or cracks in any area outside the friction surface.

4.2.2.2. Vehicles of categories M<sub>2</sub>, M<sub>3</sub>, N<sub>2</sub> and N<sub>3</sub>

4.2.2.2.1. Test conditions (brake drum high load test)

See above paragraph 4.2.1.2.1.

4.2.2.2.2. Test program (brake drum high load test)

Table A11/4.2.2.2.2.

Test provision	High load test
Type of braking	Braking to less than 5 km/h
Total number of brake applications	150
Initial brake drum temperature at each brake application	≤ 100 °C
Brake applications from to	60 km/h ≤ 5 km/h
Brake torque in accordance with a	6 m/s <sup>2</sup>
Cooling (also deviating from paragraph 3.2.3. of this annex)	permitted

4.2.2.2.3. Test result (brake drum high load test)

The test result is positive provided the brake drum does not fracture.

## Annex 12

### Requirements for replacement brake discs/drums for vehicles of category O

#### 1. Test overview

The tests required in paragraph 5.3. of this Regulation are detailed as follows according to the vehicle category:

Table A12/1A

#### Vehicles of categories O<sub>1</sub>, O<sub>2</sub> and O<sub>3</sub>

<i>Track test</i>	<i>Alternative dynamometer test (Alternative to track test)</i>
2.2.1. Type 0	3.4.1. Type 0
2.2.2. Type I	3.4.2. Type I
2.3. Parking brake system (if applicable)	–
2.4. Testing the dynamic frictional properties (comparison test conducted on the individual axles)	3.5. Testing the dynamic frictional properties (comparison test conducted on the individual axles)

Table A12/1B

#### Vehicles of categories O<sub>4</sub>

<i>Track test</i>	<i>Alternative dynamometer test (Alternative to track test)</i>
2.2.1. Type 0	3.4.1. Type 0
2.2.3. Type III	3.4.3. Type III
2.3. Parking brake system (if applicable)	–
2.4. Testing the dynamic frictional properties (comparison test conducted on the individual axles)	3.5. Testing the dynamic frictional properties (comparison test conducted on the individual axles)

#### 2. Verification of the vehicle test requirements

##### 2.1. Test vehicle

A vehicle that is representative for the selected test group (see definition in paragraph 5.3.6. of this Regulation) in respect of which an approval or parts report for a replacement brake disc/drum is applied for shall be fitted with this replacement brake disc/drum as well as be equipped with test devices for testing the brakes pursuant to the provisions of Regulation No. 13.

The replacement brake disc/drum shall be fitted to the axle in question together with an accompanying brake lining which has been type approved according to Regulations No. 13, or 90 available from the vehicle or axle manufacturer. Unless a uniform procedure is laid down for how braking is to be effected, the test shall be carried out following agreement with the Technical Service. All the tests listed below shall be carried out on brakes that have been bedded in. The same "bedding-in" programme shall be used for both replacement and original brake discs and drums.

- 2.2. Service braking system
- 2.2.1. Type 0 brake tests, vehicle laden  
This test shall be carried out pursuant to Regulation No. 13, Annex 4, paragraph 1.4.4.
- 2.2.2. Type I brake tests  
This test shall be carried out pursuant to Regulation No. 13, Annex 4, paragraph 1.5.2.  
At the end of the Type I brake test, the performance when the brakes are hot is to be satisfied pursuant to Regulation No. 13, Annex 4, paragraph 1.5.3.
- 2.2.3. Type III brake tests  
This test shall be carried out pursuant to Regulation No. 13, Annex 4, paragraph 1.7.
- 2.3. Parking braking system (if applicable)
- 2.3.1. If the service brake system and the parking brake system use a common disc or drum friction surface, it is not necessary to conduct a specific parking brake system test. The satisfactory achievement of the Type 0 laden test shall be taken as meeting the parking brake system requirements.
- 2.3.2. Static test with 18 per cent gradient, vehicle laden
- 2.3.3. The vehicle shall satisfy all the relevant provisions laid down in Regulation No. 13, Annex 4, paragraphs 2.3. and 3.2. that apply to this category of vehicle.
- 2.4. Testing the dynamic frictional properties (comparison test conducted on the individual axles)  
For this test, the vehicle shall be laden and all brake applications carried out on a flat road.  
The service braking system of the vehicle shall be provided with a device that separates the front-wheel brakes from the rear-wheel brakes so that they can always be operated independently of one another.  
If an approval or a parts report is required in connection with a replacement brake disc/drum for the front-wheel brakes, the rear-wheel brakes shall remain inoperative throughout the test.  
If an approval or a parts report is required in connection with a replacement brake disc/drum for the rear-wheel brakes, the front-wheel brakes shall remain inoperative throughout the test.
- 2.4.1. Performance comparison test when the brakes are cold  
With cold brakes, the performance of the replacement brake disc/drum shall be compared with the original equivalents by comparing the results of the test below.
- 2.4.1.1. Using the replacement brake disc/drum, at least six consecutive brake applications with different, gradually increasing control forces or brake pressures are carried out as part of the process up to the point at which the wheels lock, or up to a mean fully developed deceleration of 3.5 m/s<sup>2</sup>, or up

to the maximum control force permitted for this category of vehicle, in which connection the initial speed for testing purposes is 45 km/h:

Prior to each brake application, the initial temperature of the brake drum shall be  $\leq 100$  °C.

2.4.1.2. The brake test described in paragraph 2.4.1.1. also has to be carried out using the original brake disc/drum.

2.4.1.3. The dynamic frictional properties of the replacement brake disc/drum can be regarded as similar to those of the original brake disc/drum, provided the values attained in relation to the mean fully developed deceleration at the same operating pressures or control forces in the region of the upper 2/3 of the curve generated do not deviate by more than  $\pm 10$  per cent or  $\pm 0.4$  m/s<sup>2</sup> from those of the original brake disc/drum.

3. Inertia dynamometer test

3.1. Equipment of the dynamometer

For testing purposes, the dynamometer shall be fitted out with the original brake caliper or wheel brake of the vehicle concerned. The inertia dynamometer shall be equipped with a constant torque device and equipment for recording rotational speed, brake pressure, the number of revolutions after braking has commenced, brake torque, the braking period and the temperature of the brake drum on a continuous basis.

3.2. Test conditions

3.2.1. Inertia mass of the inertia dynamometer

The inertia mass of the inertia dynamometer shall be set as close as possible, with a permissible variation of  $\pm 5$  per cent, to the theoretically required value which corresponds to that part of the total inertia of the vehicle braked by the appropriate wheel. The formula used for calculation purposes is as follows:

$$I = m \cdot r_{\text{dyn}}^2$$

Where:

I = rotary inertia (kgm<sup>2</sup>);

$r_{\text{dyn}}$  = dynamic rolling radius of the tyre (m);

m = test mass (part of the maximum mass of the vehicle braked by the appropriate wheel) as stipulated by this Regulation.

3.2.1.1. Dynamic rolling radius

In calculating the inertia mass, the dynamic rolling radius ( $r_{\text{dyn}}$ ) of the largest tyre authorised for the vehicle (or the axle) shall be taken into account.

3.2.1.2. Test mass

The test mass for calculating the inertia mass shall be as follows:

$$m = \frac{0.55 \cdot m_{\text{veh}}}{2 \cdot n}$$

$m_{\text{veh}}$  = max. permitted mass of the vehicle  
n = number of axles, or number of front or rear-axles in the case of full trailer

- 3.2.2. The initial rotational speed of the dynamometer shall correspond to the linear speed of the vehicle at 40 or 60 km/h (depending on the type of test) based on the mean of the dynamic rolling radii of the largest and smallest tyre of the authorised tyre sizes.
- 3.2.3. Cooling
- The cooling may be carried out either to paragraphs 3.2.3.1. or 3.2.3.2.
- 3.2.3.1. Test carried out with a complete wheel according to Regulation No. 13, Annex 11, Appendix 2, paragraph 3.2.2.
- With respect to the Type I and Type III tests air cooling at a velocity and air flow direction simulating actual conditions may be used during the heating runs, the speed of the air flow being  $v_{\text{Air}} = 0.33 v$
- Where:
- $v$  = vehicle test speed at initiation of braking.
- In other cases cooling air is not restricted.
- The temperature of the cooling air shall be the ambient temperature.
- 3.2.3.2. Test carried out without a rim
- With respect to the Type I and Type III tests during the heating runs no cooling is allowed.
- In other cases cooling air is not restricted.
- 3.2.4. Preparation of the brake
- 3.2.4.1. Disc brakes
- This test is conducted using a new disc with new brake lining assemblies which have been type approved according to Regulation No. 13 or 90 (in the condition as mounted on the vehicle, e.g. protective grease removed).
- 3.2.4.2. Drum brakes
- The test is conducted using a new drum with new linings assemblies which have been type approved according to Regulation No. 13 or 90 (if applicable, protective grease removed).
- Machining of the linings to achieve good lining to drum contact is permissible.

3.3. Alternative dynamometer performance test

Table A12/3.3.

1.	Cold Bedding-in (cold burnishing): 100 (disc) or 200 (drum) brake applications $T_i = 150\text{ °C}$ (disc) or $100\text{ °C}$ (drum) $v_i = 60\text{ km/h}$ $d_m = 1$ and $2\text{ m/s}^2$ alternating
2.	Dynamic friction properties, see paragraph 3.5.1. of this annex
3.	Hot Bedding-in (Hot burnishing): Make 30 consecutive snub applications with $v_1 = 60\text{ km/h}$ and $v_2 = 30\text{ km/h}$ with a cycle time of 60 s starting at a brake temperature of $\leq 100\text{ °C}$ at the first application. The deceleration of the first application shall be constant $3\text{ m/s}^2$ . From the second up to the last application the pressure shall be constant and equivalent to the average of the first application.
4.	Re-burnishing: 30 brake applications $T_i = 150\text{ °C}$ (disc) or $100\text{ °C}$ (drum) $v_i = 60\text{ km/h}$ , $d_m = 1$ and $2\text{ m/s}^2$ alternating
5.	Brake test Type 0, see paragraph 3.4.1. of this annex
6.	Brake test Type I (in the case of $O_2/O_3$ ), see paragraph 3.4.2. of this annex
7.	Re-burnishing: (like item 4.)
8.	Brake test Type 0, see paragraph 3.4.1. of this annex
9.	Brake test Type III ((in the case of $O_4$ ), see paragraph 3.4.3. of this annex
10.	Re-burnishing: (like item 4.)

3.4. Service braking system

3.4.1. Brake tests Type 0, vehicle laden

This test shall be carried out analogous to the provisions of Regulation No. 13, Annex 4, paragraph 1.4.4.

3.4.2. Brake tests Type I

This test shall be carried out analogous to the provisions of Regulation No. 13, Annex 4, paragraph 1.5.2.

At the end of the Type I brake test, the performance when the brakes are hot is to be satisfied pursuant to Regulation No. 13, Annex 4, paragraph 1.5.3.

- 3.4.3. Brake tests Type III
- This test shall be carried out analogous to the provisions of Regulation No. 13, Annex 4, paragraph 1.7.
- 3.5. Testing the dynamic frictional properties (comparison test conducted on the individual wheel brake)
- 3.5.1. The test shall be carried out in accordance of Regulation No. 13, Annex 19, paragraphs 4.4.3.1. to 4.4.3.4.
- 3.5.2. The brake test described in paragraph 3.5.1. also has to be carried out using the original brake disc/drum.
- 3.5.3. The dynamic frictional properties at step 2 of the procedure of the replacement brake disc/drum can be regarded as similar to those of the original brake disc/drum, provided the values attained in relation to the mean fully developed deceleration at the same operating pressures or control forces in the region of the upper 2/3 of the curve generated do not deviate by more than  $\pm 8$  per cent or  $\pm 0.4$  m/s<sup>2</sup> from those of the original brake disc/drum.
4. Integrity tests using an inertia dynamometer
- The tests are conducted in accordance with paragraph 4.1. (discs) or 4.2. (drums).
- A single test per test group is required unless the replacement part does not achieve the required number of cycles before damage or failure (see paragraph 4.1.1.1.3. or 4.1.1.2.3. of this annex).
- The brake should be installed on the dynamometer in accordance with its fitting position on the vehicle (rigidly mounted brakes or those installed by means of a stub axle are exempt).
- The temperature of the brake disc/brake drum should be measured in as close proximity to the friction rubbing surface as possible. The temperature measurement should be recorded and the method and measuring point shall be the same for all tests.
- If cooling air is used during a brake application or between brake applications inside one braking cycle, the speed of the airflow at the brake shall be limited to:
- $$v_{\text{air}} = 0.33 v$$
- Where:
- $v$  = vehicle test speed at initiation of braking.
- In other cases cooling air is not restricted.
- The temperature of the cooling air shall be the ambient temperature.
- 4.1. Brake discs
- 4.1.1. Brake disc thermal fatigue test
- This test is conducted using a new disc with new brake lining assemblies which have been type approved according to Regulation No. 13 or 90 (in the condition as mounted on the vehicle, e.g. protective grease removed).

4.1.1.1. Vehicles of categories O<sub>1</sub> and O<sub>2</sub>

4.1.1.1.1. Test conditions (brake disc thermal fatigue)

The inertia mass of the inertia dynamometer shall be determined in accordance with the requirements laid down in paragraphs 3.2.1., 3.2.1.1. and 3.2.1.2. of Annex 12.

The rotational speed of the dynamometer shall correspond to the linear test speed of the vehicle based on the mean of the largest and smallest dynamic rolling radius of the tyres authorized for that vehicle.

4.1.1.1.2. Test program (brake disc thermal fatigue)

Table A12/4.1.1.1.2.

Test provision	Thermal fatigue test
Vehicle categories	O <sub>1</sub> , O <sub>2</sub>
Type of braking	Sequential brake applications
Braking interval (= t <sub>total</sub> )	70 s
Number of brake applications per cycle	2
Brake torque in accordance with a [m/s <sup>2</sup> ]	5.0
Total number of braking cycles	100 or 150 (see paragraph 4.1.1.1.3.)
Brake applications	
from	80 km/h
to	20 km/h
Initial temperature of the 1st brake application in each cycle	≤ 100 °C

v<sub>max</sub> maximum design speed (as per its range of use);

t<sub>bra</sub> actual braking period during the application;

t<sub>acc</sub> minimum acceleration time in accordance with the accelerating power of the respective vehicle;

t<sub>rest</sub> rest period;

t<sub>total</sub> Braking interval (t<sub>bra</sub> + t<sub>acc</sub> + t<sub>rest</sub>).

4.1.1.1.3. Test result (brake disc thermal fatigue test)

The test is regarded as having been passed if 150 or more cycles are completed without damage or failure.

If less than 150 cycles but more than 100 cycles are completed without damage or failure then the test must be repeated on a new replacement part. Under these circumstances both tests must complete more than 100 cycles without damage or failure for the part to have passed the test.



If less than 100 cycles are completed before damage or failure then a test should be conducted on the original part and the results compared. If the damage or failure point is no worse than the number of cycles of the original part -10 per cent then the test is regarded as having been passed.

Damage in this context means:

- (a) Radial cracks on the friction surface which are longer than 2/3 of the radial height of the friction surface;
- (b) Cracks on the friction surface which reach the inner or outer diameter of the friction surface;
- (c) Through-cracking of any friction ring;
- (d) Any type of structural damage or cracks in any area outside the friction surface.

4.1.1.2. Vehicles of categories O<sub>3</sub> and O<sub>4</sub>

4.1.1.2.1. Test conditions (brake disc thermal fatigue test)

4.1.1.2.1.1. Vehicles with a maximum permissible mass > 7.5 t

By means of the following test program, brake discs are tested as components of the braking system. It does not imitate actual driving conditions but is understood as being purely a component test. The parameters listed below in Table A12/4.1.1.2.1.1. cover the brakes that are presently used as a rule on vehicles with a maximum permitted mass > 7.5 t.

Table A12/4.1.1.2.1.1.

Outside disc diameter	Test parameter	Test parameter	Example of equipment
	Test mass <i>m</i> [kg]	<i>r</i> <sub>dyn</sub> [m]	"Brake size"/smallest possible rim size
320-350	3,100	0.386	17.5"
351-390	4,500	0.445	19.5"
391-440	5,300	0.527	22.5"
> 440*	*	*	—

\* The test mass and the dynamic tyre rolling radius to be agreed between the applicant and the Technical Service.

The inertia mass of the inertia dynamometer shall be determined in accordance with the requirements laid down in paragraph 3.2.1. of Annex 12 in conjunction with the parameters specified in the table above (test mass and *r*<sub>dyn</sub>).

The rotational speed of the dynamometer shall correspond to the linear test speed of the vehicle based on the dynamic tyre rolling radii specified in Table A12/4.1.1.2.1.1.

4.1.1.2.1.2. Vehicles with a maximum permissible mass > 3.5 t and ≤ 7.5 t

As regards vehicles with a maximum permitted mass > 3.5 t and ≤ 7.5 t in respect of which the parameters listed in Table A12/4.1.1.2.1.1. do not apply, the test parameters shall be selected in such a way that the worst case scenario that formed the basis of the range of use of the replacement brake disc (maximum permitted vehicle mass, maximum tyre equipment size) is covered.

The inertia mass of the inertia dynamometer shall be determined in accordance with the requirements laid down in paragraphs 3.2.1., 3.2.1.1. and 3.2.1.2. of Annex 12.

The rotational speed of the dynamometer shall correspond to the linear test speed of the vehicle based on the mean of the largest and smallest dynamic rolling radius of the tyres authorised for that vehicle.

4.1.1.2.2. Test program (brake disc thermal fatigue test)

Table A12/4.1.1.2.2.

"Bedding-in" procedure	100 Brake applications Initial speed: 60 km/h Final speed: 30 km/h $d_m$ alternating between 1 m/s <sup>2</sup> und 2 m/s <sup>2</sup> Initial temperature: ≤ 300 °C (beginning at room temperature)
1. Conditioned braking	10 Brake applications from 60 to 30 km/h $d_m$ alternating between 1 m/s <sup>2</sup> und 2 m/s <sup>2</sup> Initial temperature : ≤ 250 °C
2. High-speed braking	2 Brake applications from 130 to 80 km/h $d_m = 3$ m/s <sup>2</sup> Initial temperature: ≤ 100 °C
3. Conditioned braking	See test stage 1
4. High-speed braking	See test stage 2
5. Conditioned braking	See test stage 1
6. Continuous braking (1)	5 Brake applications at a constant speed of: 85 km/h Decelerating torque corresponding to 0.5 m/s <sup>2</sup> Braking period 60 s Initial temperature: ≤ 80 °C
7. Conditioned braking	see test stage 1
8. Continuous braking (2)	5 Brake applications at a constant speed of: 85 km/h Decelerating torque corresponding to 1.0 m/s <sup>2</sup> Braking period 40 s Initial temperature: ≤ 80 °C
9. Repeat test stages 1 to 8:	9 or 14 times (whichever is applicable) – see paragraph 4.1.1.2.3.

$d_m$  distance-related mean deceleration.

4.1.1.2.3. Test result (brake disc thermal fatigue test)

The test is regarded as having been passed if 15 or more cycles are completed without damage or failure.

If less than 15 cycles but more than 10 cycles are completed without damage or failure then the test must be repeated on a new replacement part. Under these circumstances both tests must complete more than 10 cycles without damage or failure for the part to have passed the test.

If less than 10 cycles are completed before damage or failure then a test should be conducted on the original part and the results compared. If the damage or failure point is no worse than the number of cycles of the original part then the test is regarded as having been passed.

Damage in this context means:

- (a) Radial cracks on the friction surface which are longer than 2/3 of the radial height of the friction surface;
- (b) Cracks on the friction surface which reach the inner or outer diameter of the friction surface;
- (c) Through-cracking of any friction ring;
- (d) Any type of structural damage or cracks in any area outside the friction surface.

4.1.2. Brake disc high load test

The high load tests shall be conducted on the same test specimens following on from the alternative dynamometer test (see paragraph 3.3. of this annex).

4.1.2.1. Vehicles of categories O<sub>1</sub> and O<sub>2</sub>

Not applicable.

4.1.2.2. Vehicles of categories O<sub>3</sub> and O<sub>4</sub>

4.1.2.2.1. Test conditions (brake disc high load test)

See above paragraph 4.1.1.2.1.

4.1.2.2.2. Test program (brake disc high load test)

500 brake applications are carried out from a speed of 50 km/h to 10 km/h with a brake torque of 90 per cent of the maximum brake torque specified by the applicant.

Initial temperature:  $\leq 200$  °C

4.1.2.2.3. Test result (brake disc high load test)

The test is regarded as having been passed if the brake disc does not exhibit any signs of fracture after 500 brake applications.

4.2. Brake drums

4.2.1. Brake drum thermal fatigue test

The test is conducted using a new drum with new linings assemblies which have been type approved according to Regulation No. 13, 13-H or 90 (if applicable, protective grease removed).

Machining of the linings to achieve good lining to drum contact is permissible.

4.2.1.1. Vehicles of categories O<sub>1</sub> and O<sub>2</sub>

4.2.1.1.1. Test conditions (brake drum thermal fatigue test)

4.2.1.1.1.1. Vehicles with a maximum permissible axle load ≤ 1,200 kg

Not applicable.

4.2.1.1.1.2. Vehicles with a maximum permissible axle load > 1,200 kg

The inertia mass of the inertia dynamometer shall be determined in accordance with the requirements laid down in paragraphs 3.2.1., 3.2.1.1. and 3.2.1.2. of Annex 12.

The rotational speed of the dynamometer shall correspond to the linear test speed of the vehicle based on the mean of the largest and smallest dynamic rolling radius of the tyres authorized for that vehicle.

4.2.1.1.2. Test program (brake drum thermal fatigue test)

Table A12/4.2.1.1.2.

Test provision	Thermal fatigue test
Type of braking	Sequential brake applications
Number of brake applications	250 or 300 (whichever is applicable) – see 4.2.1.1.3. <i>NB:</i> The test is interrupted when a through crack appears.
Brake torque set to produce a deceleration of	3.0 m/s <sup>2</sup>
Brake applications from to	130 80 km/h
Initial temperature of each brake application	≤ 50 °C
Cooling pursuant to 3.2.3.	permitted

4.2.1.1.3. Test result (brake drum thermal fatigue test)

The test is regarded as having been passed if 450 or more brake applications are completed without damage or failure.

If less than 450 brake applications but more than 300 brake applications are completed without damage or failure then the Technical Service must repeat the test on a new replacement part. Under these circumstances both tests must complete more than 300 brake applications without damage or failure for the part to have passed the test.

If less than 300 brake applications are completed before damage or failure then a test should be conducted on the original part and the results compared – if the damage or failure point is no worse than the original part then the test is regarded as having been passed.

Damage in this context means:

- (a) Cracks on the friction surface which are longer than 2/3 of the axial width of the friction surface;
- (b) Cracks on the friction surface which reach the axial outer end of the drum;
- (c) Through-cracking of the drum;
- (d) Any type of structural damage or cracks in any area outside the friction surface.

4.2.1.2. Vehicles of categories O<sub>3</sub> and O<sub>4</sub>

4.2.1.2.1. Test conditions (brake drum thermal fatigue test)

4.2.1.2.1.1. Vehicles with a maximum permissible mass > 7.5 t

By means of the following Test program, brake discs are tested as components of the braking system. It does not imitate actual driving conditions but is understood as being purely a component test. The parameters listed below in Table A12/4.2.1.2.1.1. cover the brakes that are presently used as a rule on vehicles with a maximum permitted mass > 7.5 t.

Table A12/4.2.1.2.1.1.

Inner drum diameter [mm]	Lining width						Typical rim diameter
	< 130 mm		130 -190 mm		>190 mm		
	Test mass [kg]	Tyre radius [m]	Test mass [kg]	Tyre radius [m]	Test mass [kg]	Tyre radius [m]	
< 330	2,750	0.402	3,200	0.390	5,500	0.402	17.5"
330-390	*	*	3,400	0.480	5,500	0.516	19.5"
391-430	3,400	0.510	4,500	0.527	5,500	0.543	22.5"
> 430	*	*	*	*	*	*	—

\* The test mass and the dynamic tyre rolling radius to be agreed between the applicant and the Technical Service.

The inertia mass of the inertia dynamometer shall be determined in accordance with the requirements laid down in paragraph 3.2.1. of Annex 12 in conjunction with the parameters specified in the table above (test mass and  $r_{dyn}$ ).

The rotational speed of the dynamometer shall correspond to the linear test speed of the vehicle based on the dynamic tyre rolling radii specified in Table A12/4.2.1.2.1.1.

4.2.1.2.1.2. Vehicles with a maximum permissible mass > 3.5 t and ≤ 7.5 t

As regards vehicles with a maximum permitted mass > 3.5 t and ≤ 7.5 t in respect of which the parameters listed in Table A12/4.1.1.2.1.1. do not apply, the test parameters shall be selected in such a way that the worst case scenario that formed the basis of the range of use of the replacement brake disc (maximum permitted vehicle mass, maximum tyre equipment size) is covered.

The inertia mass of the inertia dynamometer shall be determined in accordance with the requirements laid down paragraphs 3.2.1., 3.2.1.1. and 3.2.1.2. of Annex 12.

The rotational speed of the dynamometer shall correspond to the linear test speed of the vehicle based on the mean of the largest and smallest dynamic rolling radius of the tyres authorized for that vehicle.

4.2.1.2.2. Test program (brake drum thermal fatigue test)

Table A12/4.2.1.2.2.

Test provision	Thermal fatigue test
Type of braking	Sequential brake applications
Number of brake applications	250 or 300 (whichever is applicable) – see 4.2.1.2.3. <i>NB:</i> The test is interrupted when a through crack appears.
Brake torque set to produce a deceleration of	3.0 m/s <sup>2</sup>
Brake applications from to	130 80 km/h
Initial temperature of each brake application	≤ 50 °C
Cooling pursuant to paragraph 3.2.3.	permitted

4.2.1.2.3. Test result (brake drum thermal fatigue test)

The test is regarded as having been passed if 300 or more brake applications are completed without damage or failure.

If less than 300 brake applications but more than 250 brake applications are completed without damage or failure then the Technical Service must repeat the test on a new replacement part. Under these circumstances both tests must complete more than 250 brake applications without damage or failure for the part to have passed the test.

If less than 250 brake applications are completed before damage or failure then a test should be conducted on the original part and the results compared – if the damage or failure point is no worse than the original part then the test is regarded as having been passed.

Damage in this context means:

- (a) Cracks on the friction surface which are longer than 2/3 of the axial width of the friction surface;
- (b) Cracks on the friction surface which reach the axial outer end of the drum;
- (c) Through-cracking of the drum;
- (d) Any type of structural damage or cracks in any area outside the friction surface.

- 4.2.2. Brake drum high load test  
The high load test shall be conducted on the same test specimens following the alternative dynamometer test (see paragraph 3.3. of this annex.)
- 4.2.2.1. Vehicles of categories O<sub>1</sub> and O<sub>2</sub>
- 4.2.2.1.1. Test conditions (brake drum high load test)  
See paragraph 4.2.1.1.1. above.
- 4.2.2.1.2. Test program (brake drum high load test)  
See paragraph 4.2.2.2.2. below.
- 4.2.2.1.3. Test result (brake drum high load test)  
See paragraph 4.2.2.2.3. below.
- 4.2.2.2. Vehicles of categories O<sub>3</sub> and O<sub>4</sub>
- 4.2.2.2.1. Test conditions (brake drum high load test)  
See paragraph 4.2.1.2.1. above.
- 4.2.2.2.2. Test program (brake drum high load test)

Table A12/4.2.2.2.2.

Test provision	High load test
Type of braking	Braking to standstill
Total number of brake applications	150
Initial temperature of the brake drum every time the brake is operated	≤ 100 °C
Brake applications from to	60 km/h 0 km/h
Brake torque set to produce a deceleration of	6 m/s <sup>2</sup>
Cooling (also deviating from paragraph 3.2.3.)	permitted

- 4.2.2.2.3. Test result (brake drum high load test)  
The test result is positive provided the brake drum does not fracture.

## Annex 13

### Model test report for a replacement brake disc/drum

**Test Report No. ... concerning the approval of a replacement brake disc/drum in accordance to Regulation No. 90**

1. General technical description of a replacement brake disc/drum<sup>1</sup>
  - 1.1. Applicant (name and address): .....
  - 1.2. Manufacturer (name and address): .....
  - 1.3. Trade name: .....
  - 1.4. Category of replacement disc/drum: Original/Identical/Equivalent/Interchangeable<sup>1</sup>
  - 1.5. Type of disc/drum<sup>1</sup>: .....
  - 1.6. Marking:

	<i>Identification</i>	<i>Location of marking</i>	<i>Method of marking</i>
Manufacturer name or trade name:			
Approval number	E2-90R02 Cxxxx/yyyy		
	xxxx => Type No. yyyy => Variant No.		
Indication for traceability			
Minimum thickness (disc)/maximum inside diameter (drum) <sup>1</sup>			

- 1.7. Material
  - 1.7.1. Material group: .....
  - 1.7.2. Material subgroup<sup>2</sup>: .....

<sup>1</sup> Strike out what does not apply.

<sup>2</sup> If applicable.



1.8. Application range

With minimum of the following information:

<i>Part</i>			
<i>Replacement part</i>		<i>Original part</i>	
<i>Variant</i>	<i>part number</i>	<i>part number</i>	<i>identification code</i>

<i>Motor-vehicle<sup>2</sup></i>					
<i>Make</i>	<i>Type of vehicle</i>	<i>Trade name</i>	<i>Maximum Gross weight</i>	<i>Maximum speed</i>	<i>Year of manufacture</i>

<i>Axle for trailers<sup>2</sup></i>					
<i>Make</i>	<i>Type of axle</i>	<i>Trade name</i>	<i>Maximum axle load</i>	<i>Range of dynamic tyre radius (largest / smallest)</i>	

<i>Brake</i>				
<i>Position</i>		<i>Calliper<sup>2</sup></i>	<i>Dimensions</i>	<i>Type of construction</i>
<i>Front</i>	<i>Rear</i>			

1.9. Additional information<sup>2</sup>

2. Test Groups

2.1. Dimensions per test group

2.1.1. Outside (disc)/Inside (drum)<sup>1</sup> diameters:.....

2.1.2. Thickness (disc)/Shoe width (drum)<sup>1</sup> diameters: .....

2.2. Highest ratio of kinetic energy per test group in according to paragraph 5.3.6. of Regulation No. 90

$$\text{Max} \left( \frac{E_i}{m_{\text{replacement part, i}}} \right) = \dots\dots\dots$$

2.3. Disc/drum<sup>1</sup> material per test group: .....

- 
- 3. Technical data regarding the tests per test group
    - 3.1. Vehicle test
      - 3.1.1. Data of the test vehicle
        - 3.1.1.1. Vehicle category: .....
        - 3.1.1.2. Vehicle manufacturer: .....
        - 3.1.1.3. Vehicle make: .....
        - 3.1.1.4. Vehicle type and trade name:.....
        - 3.1.1.5. Vehicle identification number: .....
        - 3.1.1.6. Vehicle type approval No.: .....
        - 3.1.1.7. Vehicle engine power: .....
        - 3.1.1.8. Speed:
          - Maximum vehicle speed  $v_{max}$ :.....
        - 3.1.1.9. Tyres:.....
        - 3.1.1.10. Brake circuit configuration/Layout:.....
        - 3.1.1.11. Test masses
          - Axle 1: .....
          - Axle 2: .....
          - Axle...: .....
        - 3.1.1.12. Brake:
          - 3.1.1.12.1. Test sample brake disc/Brake drum<sup>1</sup>:
            - Identification code of the original replacement part: .....
            - Test group:.....
            - Part number: .....
            - Mass of the replacement part:.....
            - Outside disc diameter/Inside drum diameter<sup>1</sup>: .....
            - Radius  $r_e$ , effective:.....
            - Friction surface width:.....
            - Disc thickness (nominal)/Outside drum width<sup>1</sup>: .....
          - 3.1.1.12.2. Brake calliper/Brake drum mechanism<sup>1</sup>
            - Manufacturer: .....
            - Type:.....
            - Variant: .....
            - Part number: .....
            - Method of construction:.....

- Maximum technically permissible torque  $C_{max,e}$  at the brake lever (pneumatic)/Line pressure ( $p_{max,e}$ ) (hydraulic)<sup>1</sup>:.....
- Threshold torque  $C_{0,e}$  (pneumatic)/Line pressure (hydraulic)<sup>1</sup>: .....
- Ratio  $l_e/e_e$  (pneumatic)/Piston diameter (hydraulic)<sup>1</sup>:..... / .....
- Maximum brake torque: .....
- 3.1.1.12.3. Brake pad/Brake lining<sup>1</sup>
- Manufacturer: .....
- Make: .....
- Type:.....
- Approval number<sup>2</sup>:.....
- Identification (e.g. part number):.....
- Effective surface area: .....
- 3.1.2. Test equipment
- 3.1.2.1. Deceleration:.....
- 3.1.2.2. Pressure: .....
- 3.1.2.3. Speed: .....
- 3.1.2.4. Drum/Disc temperature: .....
- 3.1.3. Test track:
- 3.1.3.1. Location:.....
- 3.1.3.2. Surface:.....
- 3.1.3.3. Condition (e.g. dry/wet):.....
- 3.2. Dynamometer test
- 3.2.1. Test data
- 3.2.1.1. Vehicle category:.....
- 3.2.1.2. Dynamic rolling radius
- Dynamic rolling radius  $R_{iner}$  for calculating the inertia:  
with respect to paragraph 3.2.1 of Annex 11/12 .....
- Dynamic rolling radius  $R_{veh}$  with respect to paragraph 3.2.2 of Annex 11/12: ..
- 3.2.1.3. Masses and inertia
- Maximum permissible mass of the vehicle:.....
- X-Value (front axle): .....
- Y-Value (rear axle):.....
- Test mass  $m$ : .....
- Test inertia  $I_{Adj}$ : .....
- 3.2.1.4. Cooling .....
- 3.2.1.4.1. Speed of cooling air during Type I, Type II and/or Type III<sup>1</sup> .....

- 3.2.1.4.2. Speed of cooling air in other cases:
- 3.2.1.5. Speed  
Maximum speed  $v_{max}$ : .....
- 3.2.1.6. Actuation device  
Manufacturer: .....  
Make: .....  
Type: .....  
Variant: .....  
Effective area (hydraulic)/ $Th_A$  – formula (pneumatic)<sup>1</sup>: .....
- 3.2.1.7. Brake
- 3.2.1.7.1. Test sample brake disc/Brake drum<sup>1</sup>  
Identification code of the original replacement part: .....  
Test group: .....  
Part number: .....  
Mass of the replacement part: .....  
Outside disc diameter/Inside drum diameter<sup>1</sup>: .....  
Radius  $r_e$ , effective: .....  
Friction surface width: .....  
Disc thickness (nominal)/Outside drum width<sup>1</sup>: .....
- 3.2.1.7.2. Brake calliper/Brake drum mechanism<sup>1</sup>  
Manufacturer: .....  
Type: .....  
Variant: .....  
Method of construction: .....  
Maximum technical permissible torque  $C_{max,e}$  at the brake lever (pneumatic)/Line pressure ( $p_{max,e}$ ) (hydraulic)<sup>1</sup>: .....  
Threshold torque  $C_{0,e}$  (pneumatic)/Line pressure (hydraulic)<sup>1</sup>: .....  
Ratio  $l_e/e_e$  (pneumatic)/Piston diameter (hydraulic)<sup>1</sup> ...../.....  
Maximum Brake torque: .....  
Identification-No.: .....
- 3.2.1.7.3. Brake pad/Brake Lining<sup>1</sup>  
Manufacturer: .....  
Make: .....  
Type: .....  
Approval number<sup>2</sup>: .....  
Identification: .....

Width  $b_e$ : .....  
Thickness  $d_e$ : .....  
Surface, effective: .....  
Method of attachment: .....

- 4. Record of Test results
- 4.1. Geometric check: .....
- Drawing No. and issue level: .....
- 4.2. Material check: .....
- 4.3. Balancing provisions check: .....
- 4.4. Wear condition marking check: .....
- 4.5. Vehicle test/Alternative dynamometer test<sup>1</sup>:
- 4.5.1. Brake performance
- 4.5.1.1. Service brake performance in the case of categories M, N<sup>2</sup>

		<i>0</i> <i>disconnected</i> <sup>2</sup>	<i>0</i> <i>connected</i>	<i>I</i>	
<i>No. of sample</i>					
Annex 11, paragraph:		2.2.1./ 3.4.1. <sup>1</sup>	2.2.2./ 3.4.4. <sup>1</sup>	2.2.3./ 3.4.2. <sup>1</sup>	
Test speed					
Initial	km/h				
Final	km/h				
Brake chamber pressure $p_e$	kPa				
Number of applications	–				
Duration of one brake cycle	s				
Brake force $0.5 \cdot T_e$	daN				
Braking ratio $0.5 \cdot T_e /$ $9.81 \cdot m$ ( $m =$ Test mass)	–				
Brake chamber stroke $s_e$	mm				
Threshold torque at the brake lever $C_e$	Nm				
$C_{0,e}$	Nm				

Free running: .....

4.5.1.2. Service brake performance in the case of categories M<sub>2</sub>, M<sub>3</sub>, N<sub>2</sub>, N<sub>3</sub><sup>2</sup>

<i>Test type:</i>		0	II	
<i>No. sample</i>				
Annex 11, paragraph:		2.2.1./ 3.4.1. <sup>1</sup>	2.2.4./ 3.4.3. <sup>1</sup>	
Test speed				
Brake chamber pressure p <sub>e</sub>	kPa			
Number of applications	–			
Duration of one brake cycle	s			
Brake force 0.5 · T <sub>e</sub>	daN			
Braking ratio 0.5 · T <sub>e</sub> / 9.81 · m (m = Test mass)	–			
Brake chamber stroke s <sub>e</sub>	mm			
Threshold torque at the brake lever C <sub>e</sub> C <sub>0,e</sub>	Nm Nm			

Free running: .....

4.5.1.3. Service brake performance in the case of categories O<sub>1</sub>, O<sub>2</sub>, O<sub>3</sub><sup>2</sup>

<i>Test type:</i>		0	I	
<i>No. sample</i>				
Annex 12, paragraph:		2.2.1./ 3.4.1. <sup>1</sup>	2.2.2./ 3.4.2. <sup>1</sup>	
Test speed				
Brake chamber pressure p <sub>e</sub>	kPa			
Number of applications	–			
Duration of one brake cycle	s			
Brake force 0.5T <sub>e</sub>	daN			
Braking ratio 0.5T <sub>e</sub> / 9.81 · m (m = Test mass)	–			
Brake chamber stroke s <sub>e</sub>	mm			
Threshold torque at the brake lever C <sub>e</sub> C <sub>0,e</sub>	Nm Nm			

Free running: .....

4.5.1.4. Service brake performance in the case of categories O<sub>4</sub><sup>2</sup>

<i>Test type:</i>		<i>0</i>	<i>III</i>
<i>No. sample</i>			
Annex 12, paragraph:		2.2.1./ 3.4.1. <sup>1</sup>	2.2.3./ 3.4.3. <sup>1</sup>
Test speed			
Initial	km/h		
Final	km/h		
Brake chamber pressure p <sub>e</sub>	kPa		
Number of applications	–		
Duration of one brake cycle	s		
Brake force 0.5T <sub>e</sub>	daN		
Braking ratio 0.5T <sub>e</sub> / 9.81 · m (m = Test mass)	–		
Brake chamber stroke s <sub>e</sub>	mm		
Threshold torque at the brake lever			
C <sub>e</sub>	Nm		
C <sub>0,e</sub>	Nm		

Free running: .....

4.5.1.5. Parking brake performance<sup>2</sup>:.....

4.5.1.6. Dynamic friction properties                      Diagram: deceleration vs pressure

4.6. Integrity tests:

4.6.1. Thermal fatigue test:

Sample No.	Cycles without damage in accordance with Annex 11: paragraphs 4.1.1.1.3./4.1.1.2.3./4.2.1.2.3.
	Annex 12: paragraphs 4.1.1.1.3./4.1.1.2.3./4.2.1.1.3./4.2.1.2.3. <sup>1</sup>

4.6.2. High load test:

Sample No.	Cycles without damage in accordance with Annex 11: paragraphs 4.1.2.1.3./4.1.2.2.3./4.2.2.1.3./4.2.2.2.3. Annex 12: paragraphs 4.1.2.2.3./4.2.2.1.3./4.2.2.2.3. <sup>1</sup>

5. Test Documents

6. Appendices

Appendix .....

7. Date of Test: .....

8. This test has been carried out and the results reported in accordance with Regulation No. 90 as last amended by the 02 series of amendments.

Technical Service conducting the test

Signed: .....

Date: .....

\_\_\_\_\_

DRAFT GHANA STANDARD